

CARVEWRIGHT

W O O D W O R K I N G S Y S T E M

Care and Maintenance of Your CarveWright's Quick Release Chuck (Commonly Referred to as the "Quick Change")

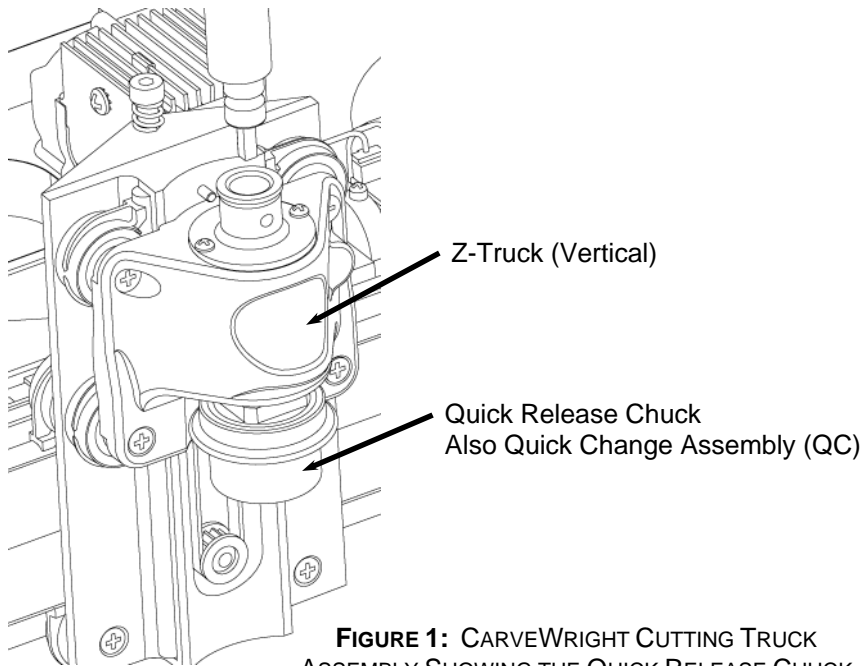

FIGURE 1: CARVEWRIGHT CUTTING TRUCK ASSEMBLY SHOWING THE QUICK RELEASE CHUCK

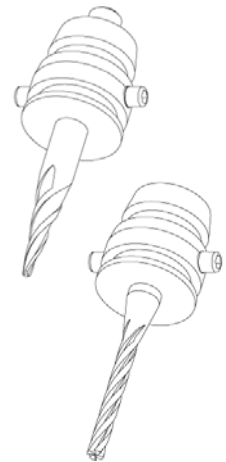

FIGURE 2: 1/16" TAPERED CARVING BIT AND 1/8" STRAIGHT CUTTING BIT ASSEMBLIES

Table of Contents

INTRODUCTION..... 2

OPERATION 2

Cocking the Quick Release Chuck..... 4

Bit Assembly Installation 4

Bit Assembly Removal..... 5

CARE AND MAINTENANCE..... 6

TROUBLESHOOTING 8

GENERAL TIPS AND HELPFUL REMINDERS..... 8

CUTTING BITS..... 9

Bit Adapter Assembly..... 10

Proper Bit Installation In the Bit Adapter 11

CarveWright Approved and Branded Bits 12

Introduction

The CarveWright™ System, with its computer-controlled 3D carving and general woodworking capabilities, is a revolutionary breakthrough in bench-top power tool design.

Central to the performance and versatility of the CarveWright machine is the patented Quick Release Chuck (or Quick Change). The CarveWright utilizes this quick release chuck system to make changing any-and-all CarveWright approved bits fast and easy. Using the patented bit adapter, the quick release chuck will accept both 1/4" and 1/2" shank bits with equal ease (please see the *Cutting Bit* section for more information on CarveWright approved bits). This means that executing complicated, multi-bit project designs is a snap; even if you are using widely varying bit sizes and profiles.

Many of the service issues encountered with the CarveWright machine occur because of improper use and/or maintenance of the quick release chuck. The goal of this document is to provide all of the information necessary to keep your quick change in top operating condition. It is important to remember that the quick release chuck may need to be replaced from time to time over the life of the machine. The quick release chuck is warranted against manufacturing defect only and is not warranted against issues related to general wear and tear.

Safety, performance, and dependability have been given top priority in the design of the CarveWright System. Please read carefully through the entire document and employ the information contained within when using your CarveWright.



WARNING or CAUTION:

Look for this symbol to point out important safety precautions. It means attention -- Personal safety is involved!



Look for this symbol to point out helpful information and hints that will allow maximum efficiency and enjoyment of the CarveWright system.

Operation

The quick release chuck operates very similar to the quick release fitting on an air hose. The three important parts of the mechanism are the chuck tapered body, the chuck spring loaded cap, and the tapered bit adapter (into which the bit is mounted). The matching tapers on the chuck body and bit adapter are precisely machined to fit together so that the bit runs vertical and true (Figure 3).

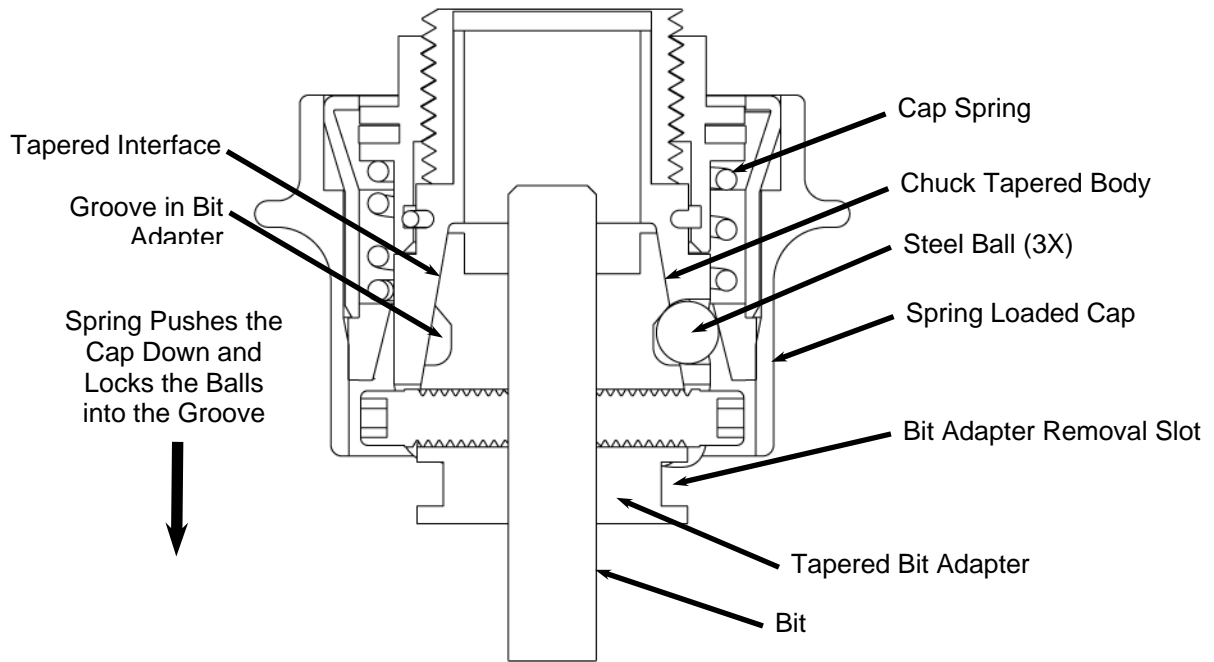

FIGURE 3: CROSS SECTION OF THE QUICK RELEASE CHUCK

There are three balls located in the chuck tapered body that fit into a groove on the bit adapter and provide the locking once the cap is forced down by the spring. Lifting up on the spring loaded cap allows the balls to retract into the tapered body and releases the bit assembly. The quick release chuck can be in two different positions: the cocked position and the bit lock position. In the cocked position, the quick change is ready to accept a bit assembly.

Visually, you can tell that the chuck is in the cocked position by looking at the bottom of the chuck. If you can see the tapered body protruding from the cap then it is cocked. Also, you can insert your finger into the tapered body and feel for the balls. If they are loose and can be pushed into the tapered body then it is in the cocked position. If the balls are locked in position then the chuck is in the non-cocked position.

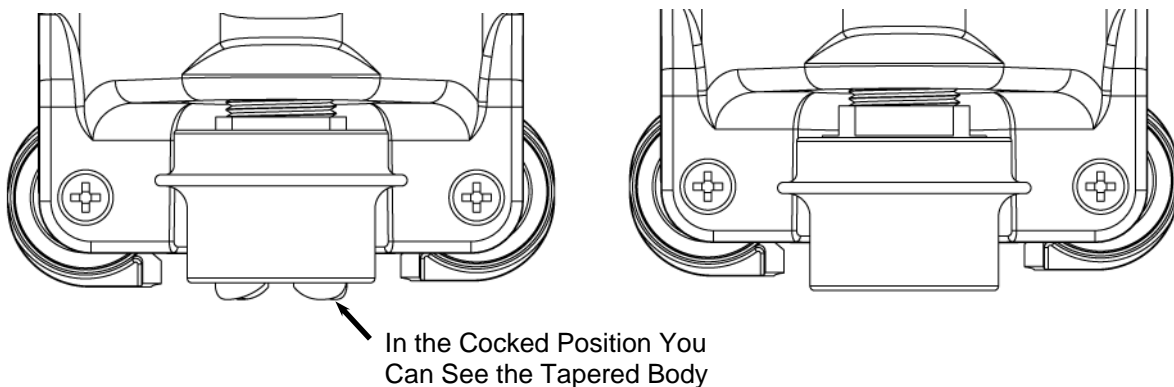

FIGURE 4: QUICK RELEASE CHUCK IN THE COCKED AND NON-COCKED POSITIONS

Cocking the Quick Release Chuck

The quick release chuck must be cocked in order to install a bit. To cock the chuck, place a thumb in the z-truck grip ridge and pull up on the chuck release flange with the middle and index fingers of the same hand. As the cap moves upward it will rotate slightly in the counter-clockwise direction relative to the tapered body. Release the flange once the top of travel is reached and it will remain in the up (or cocked) position.

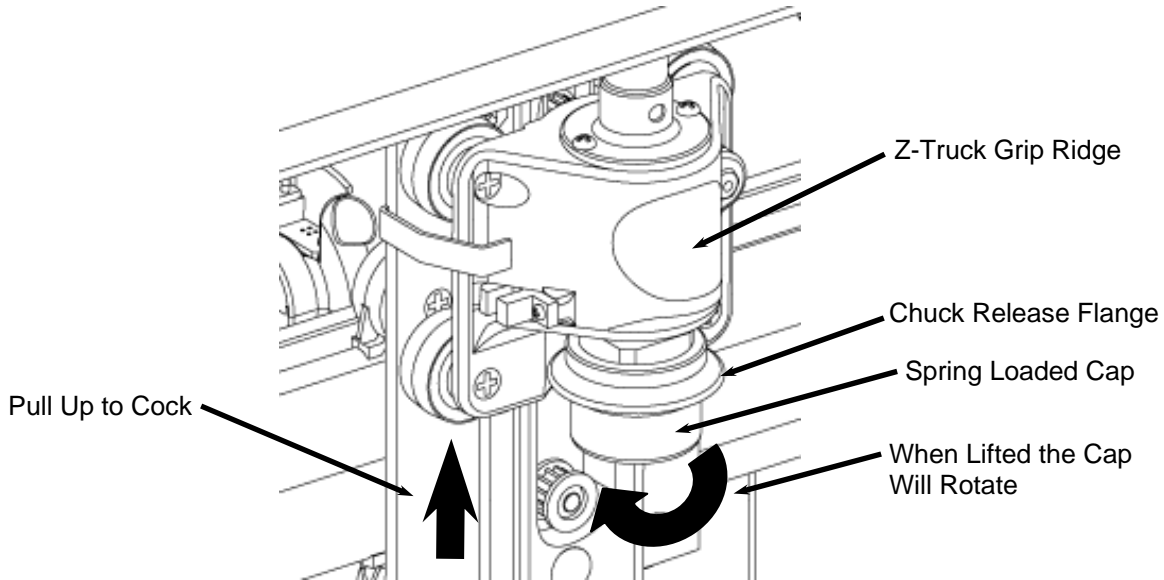

FIGURE 5: COCKING THE QUICK RELEASE CHUCK

If the cap does not stay in the cocked position repeat the above procedure applying more force to the cap. If you are unable to cock the chuck by pulling up on the flange as described insert a finger into the tapered body from below too prevent the body from rotating. Then grab and twist the spring loaded cap in the counter-clockwise direction while lifting. This should free the cap and allow the cap to be cocked.

In the event that the above methods do not result in a cocked chuck, please refer to the *Troubleshooting* section of this document for possible resolutions.

Bit Assembly Installation

Once a carving function has been selected from the display menu, the CarveWright machine will move the cutting head to the center of the machine and prompt for the user to insert the required bit.



WARNING: Use caution to avoid being cut by the razor sharp carbide cutting edges of the router bits. When touching a bit make sure to only grab non-sharpened surfaces. If this is not possible please use a cloth or glove to grab the bit.

To insert a bit into an empty chuck: lift up on the front safety cover, move the z-truck to the center and top of its travel, and cock the quick release

chuck. Without touching the z-truck or QC, press the bit assembly up until a slight snap is felt. Press down on the spring loaded cap to assure that the spring loaded cap is completely down and twist the spring loaded cap in the clockwise direction to assure that it is firmly seated

It is critically important that the bit assembly be properly assembled. Severe damage to the chuck, bit, project and even the machine can occur if the bit is not properly installed. Check the following to assure that the bit is properly installed before proceeding with a cut:

- Assure that a snap is heard when the bit is loaded into the cocked chuck
- Assure that no play can be felt at the tip of the bit once assembled into the chuck
- Assure that the bit is secure by pulling down on the bit

If any one of these three conditions is not met do **NOT** proceed with cutting. STOP, diagnose, and address problems until each condition is met. Please see the *Troubleshooting* section for a comprehensive discussion of how to diagnose and fix issues with the quick change chuck.

Bit Assembly Removal

The process for removing a bit assembly is almost identical to the one used to cock the chuck. To remove a bit assembly, place a thumb in the z-truck grip ridge and the middle and index fingers of the same hand under the chuck release flange on the spring loaded cap. Next place the middle and index fingers of the other hand around the shank of the bit. Pull up on the chuck release flange. As the cap moves upward it will rotate slightly in the counter-clockwise direction relative to the tapered body. The bit assembly should fall into your hand once the cap has been raised sufficiently. .



WARNING: Use caution to avoid being cut by the sharp cutting edges of the router bit. Use caution if the bit has recently been in use; it may be HOT and a glove will be required to handle it.

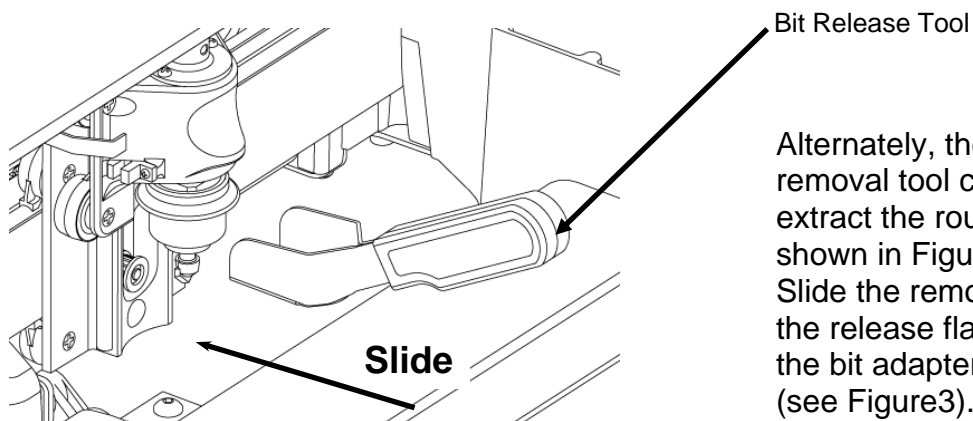

Alternately, the supplied bit removal tool can be used to extract the router bit as shown in Figures 6 and 7. Slide the removal tool under the release flange and into the bit adapter removal slot (see Figure3).

FIGURE 6: BIT REMOVAL TOOL INSERTION

Lift the handle in a gentle prying motion. The removal tool straddles the bit adapter to hold it and keep it from falling as the bit is released. The bit assembly will drop out onto the removal tool as it lifts the release flange. After removing a bit using the removal tool, the quick release chuck may be left un-cocked. To cock it, push the flange up on the chuck to prepare for insertion of another bit.

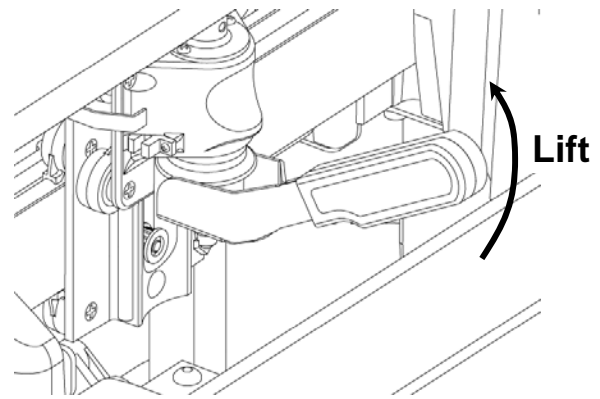

FIGURE 7: BIT RELEASE WITH TOOL

Care and Maintenance

The patented quick Release chuck is a precision machine mechanism. As with any tool, neglect of your quick release chuck will lead to many preventable problems. With proper care and maintenance the chuck will provide long, reliable service. Be sure that you routinely service your chuck by doing the following:



WARNING: Always unplug machine before attempting any troubleshooting or maintenance on the machine.

- **Check Chuck Tightness:** Take time to check the tightness of the spindle assembly before each project. This includes both the tightness of the threaded interface of the chuck to the spindle shaft as well as the slop in the spindle due to bearing wear. Any slop in the spindle will be reflected in the quality of the cut and will increase force on the chuck and bit. To check, simply insert your finger into the tapered body of the chuck from below with no bit present and move your finger back and forth checking for looseness. If you find looseness in your spindle please contact CarveWright support to diagnose the problem.
- **Remove Dust:** The CarveWright quick release chuck is designed to tolerate a considerable amount of dust. But to ensure proper operation it should be kept free of dust and debris as much as possible. Regularly blow out any dust from the recesses and the taper of the chuck. Always make sure to use low-pressure air (<80 psi) as high-pressure air can damage adjacent electronic components.

In some cases dust may be necessary to clean the chuck with a cleaning solution. We recommend that WD40 be used to clean the chuck. First lay out a rag or paper over the belt trays so as not to drip the WD40 onto the machine. Be sure to wear safety glasses as the WD40 can be an eye irritant. Use the straw nozzle to spray the WD40

up into the chuck. Work the chuck by actuating the spring loaded cap many times. If dust is limiting motion you will be able to feel it loosen as you work the cap. Spray again and continue to work the cap. Once the mechanism is working smoothly dry it with a rag and compressed air. WD40 is a degreaser so please lubricate the chuck as described below to prevent rust.

Dust can also become attached and compacted on the mating tapered surfaces because it tends to stick to the light oil needed to keep it lubricated and rust free. Keep these surfaces free of dust by cleaning them regularly.

- **Remove Pitch:** Pitch buildup can become a problem if left unchecked. Periodically remove pitch from bits, bit adapters and the internal surface of the tapered body using mineral spirits.
- **Lubricate:** It is very important that the quick release chuck is always kept properly lubricated. Keeping a thin film of oil on the chuck and bit adapters helps to deter rust, provide lubrication, and transfer heat between the bit adapter and the chuck assembly during heavy use. Periodically clean out dust from the chuck. Once cleaned, re-lubricate the chuck with a multi-purpose light oil (like 3-IN-ONE oil) on a rag. Wipe the parts down with a rag to avoid over-lubricating the chuck, as this will only attract dust and could result in staining the workpiece.
- **Prevent Rust:** The patented quick release chuck's operation can be affected by rust. Rust on any of the chuck parts or bit adapters will cause the chuck to perform poorly and eventually fail. Specifically, any rust on the surface of the mating tapers will prevent the bit adapter from sitting in the tapered body correctly. In the best case, this will cause the bit to be loose in the taper affecting cut quality and at the worst cause the bit to be thrown out of the chuck during operation. In the event that rust does appear on any of the quick release parts or bit adapters it must be removed and the parts re-lubricated. Any part with rust that penetrates deeper than the surface will need to be replaced. Do not leave bit and adapter assembled in the quick release chuck when not in use. The adapter can rust to the quick release chuck if left installed for an extended period of time.
- **Inspect Parts for Damage:** Check surface of bit adapters and surfaces for chuck for damage. Damage to mating tapered surfaces will prevent the bit adapter from sitting in the tapered body correctly. Any damaged parts must be replaced before use.
- **Check Bit and for Looseness in the Bit Adapter:** Always check that your bits are secure in the bit adapter. Loose bits will sometimes show themselves by poor cut quality and lines in the raster cuts. These lines are simply height difference caused by the bit slipping up and down in the bit adapter.

Troubleshooting

This section addresses many of the common issues that can be encountered with the quick release chuck. If the solutions presented to do solve the issue please contact CarveWright support at 713-473-6545.

Remember to always unplug machine before attempting any troubleshooting or maintenance on the machine.

- **Unable to Cock the Chuck:** In most cases a chuck that is difficult to cock is clogged with dust. This dust prevents the spring loaded cap for lifting and/or rotating entirely. In order to cock the chuck the cap must lift entirely to the top of its travel. Clean the chuck in the manner described in the *Care and Maintenance* section.
- **Bit Assembly is Stuck:** If unable to remove the bit assembly from the quick release chuck use the bit removal tool in the manner described in *Bit Assembly Removal* section. This too can be caused by dust preventing the spring loaded cap for properly lifting and rotating.
- **Cut Quality is Poor:** Poor cut quality is seen as unusually rough carving or raster carving that contain many lines in it. Something loose or misaligned in the spindle/chuck system will be the cause. There are several items to check that would cause this poor quality:
 - Bit loose in the adapter
 - Bit assembly not snapped into the tapered body correctly
 - Chuck not tightened onto the spindle
 - Worn spindle bearings
 - Chipped or damaged bit cutting surfaces (including burning)
 - Dirty bit cutting surfaces (pitch, dust, etc)
 - Damage to the tapered body because of the bit being spun out during operation
 - Dust on the tapered mating surface
 - Rust on the tapered interface surfaces
 - Bent screws on the bit adapter
 - Dimples on the bit adapter body
 - Distorted bit adapter

General Tips and Helpful Reminders



BE AWARE OF MAXIMUM CUT DEPTH. Never cut deeper than the length of the sharpened cutting surface of your bit. The maximum cut depth for the straight 1/8" cutting bit. The maximum carving depth for the 1/16" tapered carving bit is 3/4" because that is the length of the sharpened flutes. This max depth rule applies to all bits; you cannot carve deeper than the length of the sharpened cutting surface. If you program the project to go deeper than 3/4" with the carving bit you will

most likely damage your machine or bits since the stress on the machine increases exponentially when the bit is not cutting. **PLEASE** verify flute length of each bit before using.



USE ONLY QUALITY BITS. Be sure cutters are sharp and not damaged. Use only CarveWright approved cutting bits.



WHENEVER POSSIBLE KEEP THE WORKPIECE UNDER BOTH ROLLERS. It is recommended design practice to allow for at least 3.5 inches on either side of your project in order to keep the project under both compression rollers. When the workpiece is allowed to move on and off the compression rollers the sensors are unable to precisely track the board position in many circumstances. This is especially true for long workpieces.



CUT ONLY WOOD, PLASTIC OR WOOD-LIKE MATERIALS. Do not cut metal, glass, stone, tile or any other hard materials.



USE THE RIGHT BIT: Be certain to insert only the proper bit requested; damage to the workpiece and/or damage to the CarveWright machine may result from installing incorrect cutting bits.



WHEN CARVING IN PLASTIC, there are several issues to keep in mind.

Carving plastics can be very hard on the machine if the proper material is not used or if the chips are not regularly removed from the machine.

- Only Polycarbonate or Cast Acrylic plastics are approved for use in this machine. Most other common plastics melt during cutting and will damage the machine if used.
- The maximum cut depth for plastics is 0.1 inches per pass.
- Plastic shavings are prone to clogging the machine and must be vacuumed out regularly.
- Make sure that any hardware used to affix the plastic to the backer board resides outside of the cutting area.

Cutting Bits

The CarveWright machine comes equipped with two bits mounted in bit adapters. These are the 1/16" tip diameter tapered carving bit and a 1/8" straight cutting bit. Additional decorative bits (and bit adapters) are available through CarveWright.



WARNING: Piloted bits can NOT be used in the machine even if the pilot bearings have been removed..



WARNING: Use only CarveWright branded bits with the machine. The machine is calibrated to work with bits within certain specifications, and if these specifications are not met the results can be undesirable. It is possible to overstress the

machine with nonstandard bits, which could be both damaging to the machine and hazardous.

Bit Adapter Assembly

The CarveWright utilizes a patented quick release chuck system to make changing bits fast and easy. To use this system the bits must first be installed into the bit adapters. We recommend that each 1/4" bit used in the machine have its own dedicated adapter since the setscrews are required to be thread cemented. Swapping adapters will lead to stripped setscrews. In the case that the bit needs to be replaced, apply heat to the setscrews first to soften the thread cement before loosening. The bits must be spaced properly in the adapters. Please see Figure 10 and 11 for proper spacing.

For 1/2" shank bits, insert threaded bit adapter into the chuck assembly and then insert bit into threaded collet (See Figure 8) and tighten the collet with a wrench. Position the bit in the adapter as shown in Figure 10. Verify that the collet is also securely tightened.

For 1/4" steel shank bits: Remove the two setscrews from the adapter body and de-grease both the setscrews and threaded holes. This can be done using rubbing alcohol or a product such as WD40. Thoroughly dry the parts. Apply a drop of permanent thread cement on each setscrew to prevent them from loosening and start the treads. Insert the bit into the bit adapter and tighten the setscrews with supplied Allen wrench (See Figure 9). Position the bit in the adapter as shown in Figure 10 and *always make sure the setscrews are tight.*

For 1/4" carbide shank bits: Carbide bits include the 1/16" carving and 1/8" cutting bits and can be identified by the two small flats on the bit shank. Remove the two setscrews from the adapter body and de-grease both the setscrews and threaded holes. This can be done using rubbing alcohol or a product such as WD40. Thoroughly dry the parts. Apply a drop of permanent thread cement on each setscrew to prevent them from loosening and start the treads. Insert the bit into the bit adapter and position the bit so that the setscrews align to the flats. Tighten setscrews with supplied Allen wrench and *always make sure the setscrews are tight.*

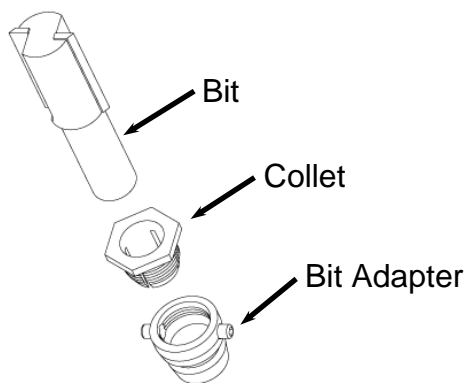

FIGURE 8: COLLET ARRANGEMENT FOR 1/2" SHANK BITS

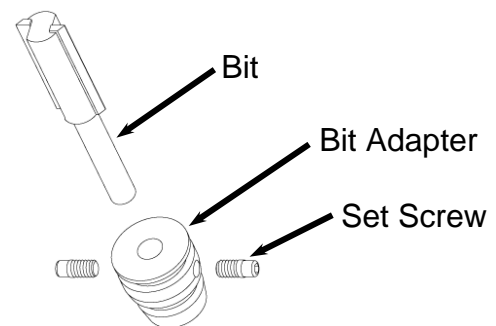

FIGURE 9: COLLET ARRANGEMENT FOR 1/4" SHANK BITS

Proper Bit Installation In the Bit Adapter

1/2" Adapter Style – Assemble the bit so that the face of the adapter is 1/8" from the bottom of the cutting surface.

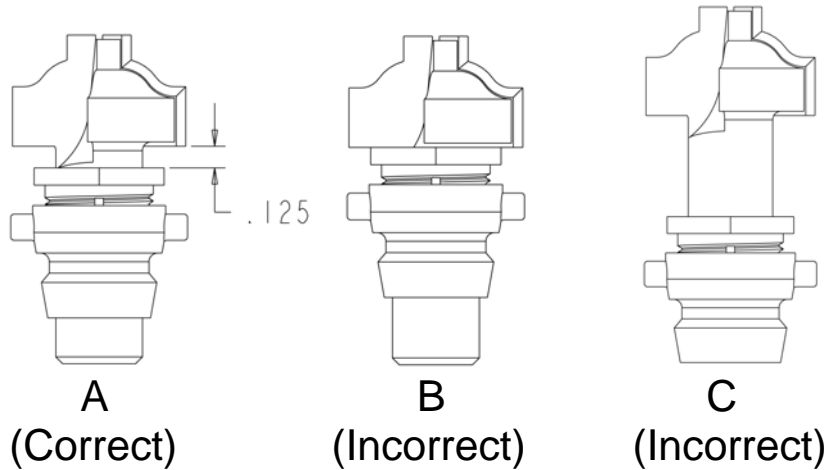

FIGURE 10: CORRECT BIT ASSEMBLY IS SHOWN IN EXAMPLE A. THE BIT IS TOO LOW IN EXAMPLE B AND TOO HIGH IN EXAMPLE C.

1/4" Adapter Style – like the 1/2" style, assemble the bit so that the face of the adapter is 1/8" from the bottom of the cutting surface. The only exception to this is the 1/4" Ball Nose bit (BBN25) and solid carbide bits. This BBN25 bit must be assembled as shown in Figure 11.

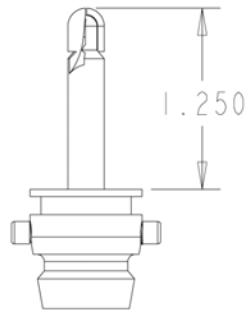

FIGURE 11: CORRECT BIT ASSEMBLY POSITION FOR 1/4" BALL NOSE BIT



WARNING: Failure to correctly install the bit in the adapter can result in injury, damage to the machine, or damage to the workpiece. This is especially true if the permanent thread cement on the 1/4" adapter setscrews is omitted.



WARNING: Check to see that each adapter is free from damage or surface defect (including rust, nicks, excess dry thread cement, etc). Adapters that have surface defects will not fit properly into the quick change and can be dislodged from the machine during operation.

CarveWright Approved and Branded Bits

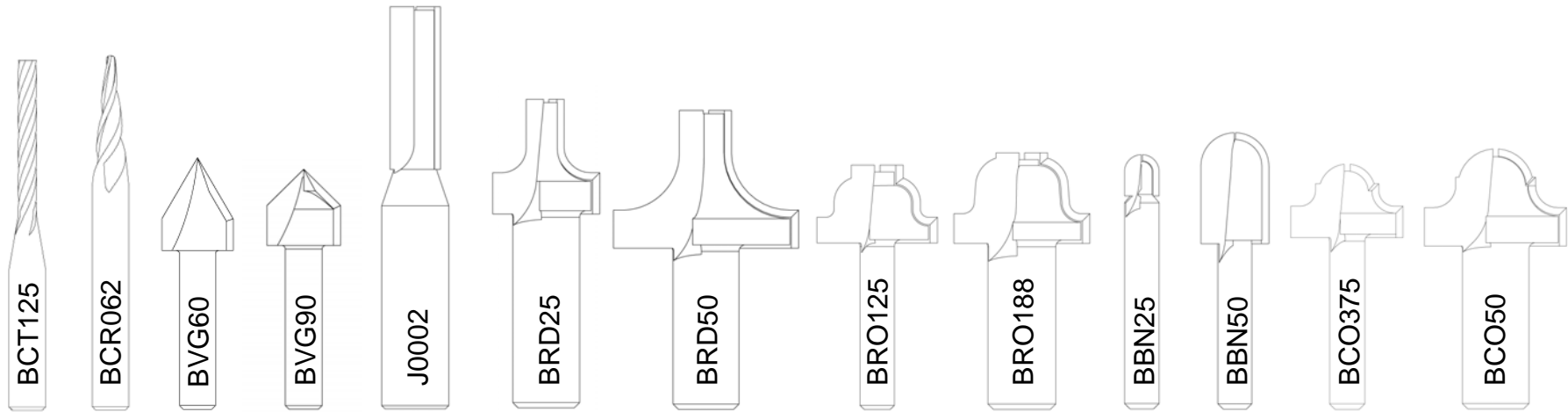

#	Bit Name	Shank	LHR P/N
A	1/8" Straight Cutting	1/4"	BCT125
B	1/16" Tapered Carving	1/4"	BCR062
C	60° V-Groove	1/4"	BVG60
D	90° V-Groove	1/4"	BVG90
E	3/8" Straight - Jointing	1/2"	J0002
F	1/4" Round-Over	1/2"	BRD25
G	1/2" Round-Over	1/2"	BRD50
H	1/8" Roman Ogee	1/4"	BRO125
I	3/16" Roman Ogee	1/2"	BRO188
J	1/4" Ball Nose	1/4"	BBN25
K	1/2" Ball Nose	1/4"	BBN50
L	3/8" Classical Ogee	1/4"	BCO375
M	1/2" Classical Ogee	1/2"	BCO50

FIGURE 12: APPROVED ROUTER BITS



WARNING: NEVER CUT DEEPER THAN THE LENGTH OF THE SHARPENED CUTTING SURFACE OF YOUR BIT. The maximum cut depth as stated in this Manual is 1" for the straight 1/8" cutting bit. The maximum carving depth for the 1/16" tapered carving bit is 3/4" because that is the length of the sharpened flutes. This max depth rule applies to all bits; you cannot carve deeper than the length of the sharpened cutting surface. If you program the project to go deeper than 3/4" with the carving bit you will most likely damage your machine or bits since the stress on the machine increases exponentially when the bit is not cutting.

Congratulations on the purchase of your



Remember These Great Resources for More Information...

- www.carverwright.com
(User's Forum, Customer Gallery, Tutorials & so much more)
- **The CarveWright Corner**
(Free Monthly Newsletter with customer spotlight, product news & contests)
- **Tips & Tricks**
(Free Monthly Newsletter with expert advice from power users)
- **The Pattern Post**
(Free Monthly Newsletter featuring new patterns and pattern vendors)
- **CarveWright Training Classes**
(Check website for next available training class date & location)
- **CarveWright Tradeshow**
(Check website to see when we are in a city near you)

Add These Must Have Accessories...

- Full Bit Set
- Project of the Month – VALUE!
- Scanning Probe
- Patterns from The Pattern Depot
- Centerline Text
- Visit Website for New Products

For more information on these Accessories visit
www.carverwright.com

***For Sales, Technical or Software Support
Call 713-473-6572
Or email support@carverwright.com***