

## Replacing the Z-truck

To remove and replace the Z-truck you will need the following tools:

1. 4mm Allen wrench
2. 12mm stamped flat wrench
3. #2 Phillips screwdriver (magnetic tip preferred)
4. Permanent thread cement

## Removing the Z-truck

1. **Ready the machine** by unplugging it from the power outlet and placing it on a stable work platform. Raise the head up several inches and move the Y-truck to the center of the machine for best access.

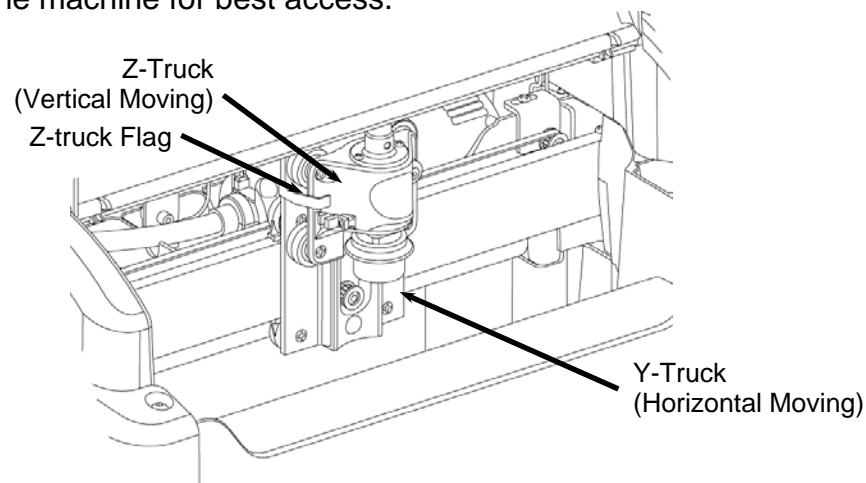


FIGURE 1: VIEW OF THE Z-TRUCK

2. **Detach the flexshaft from the top of the Z-truck:** Move the Z-truck to the very top of its travel (until it reaches the hard stop) so that the flexshaft support tube protrudes from the head cover (See Figure 2).

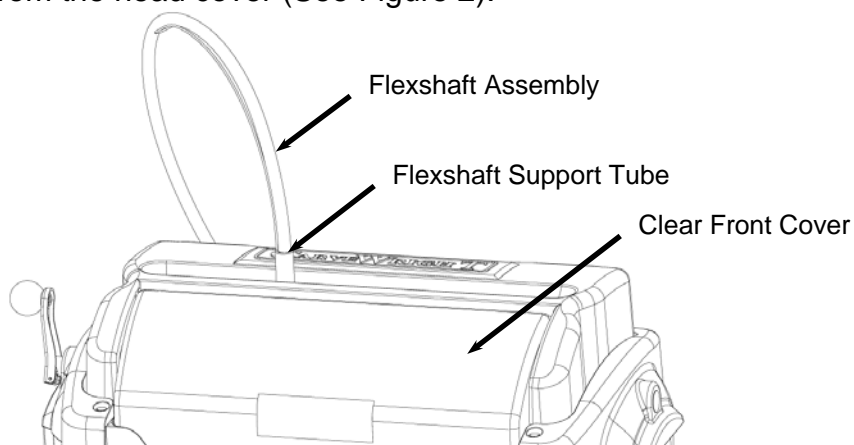
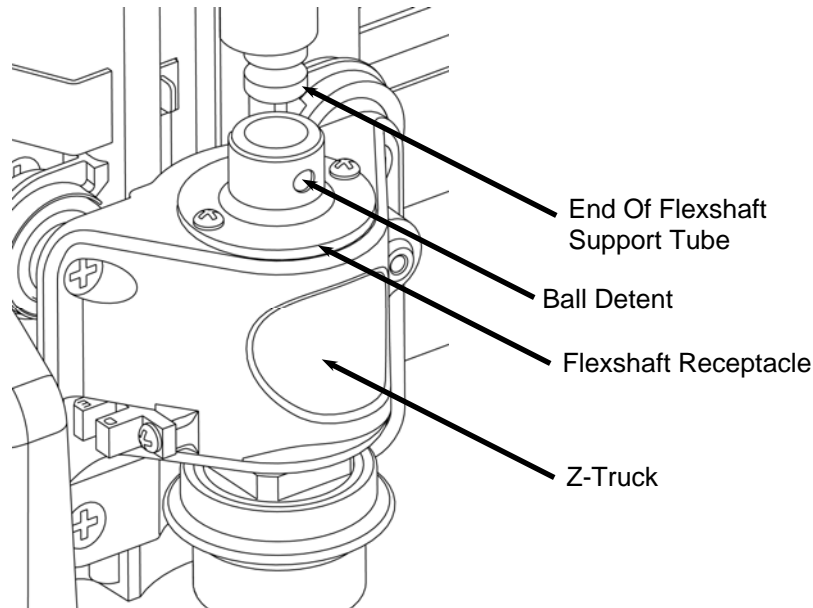


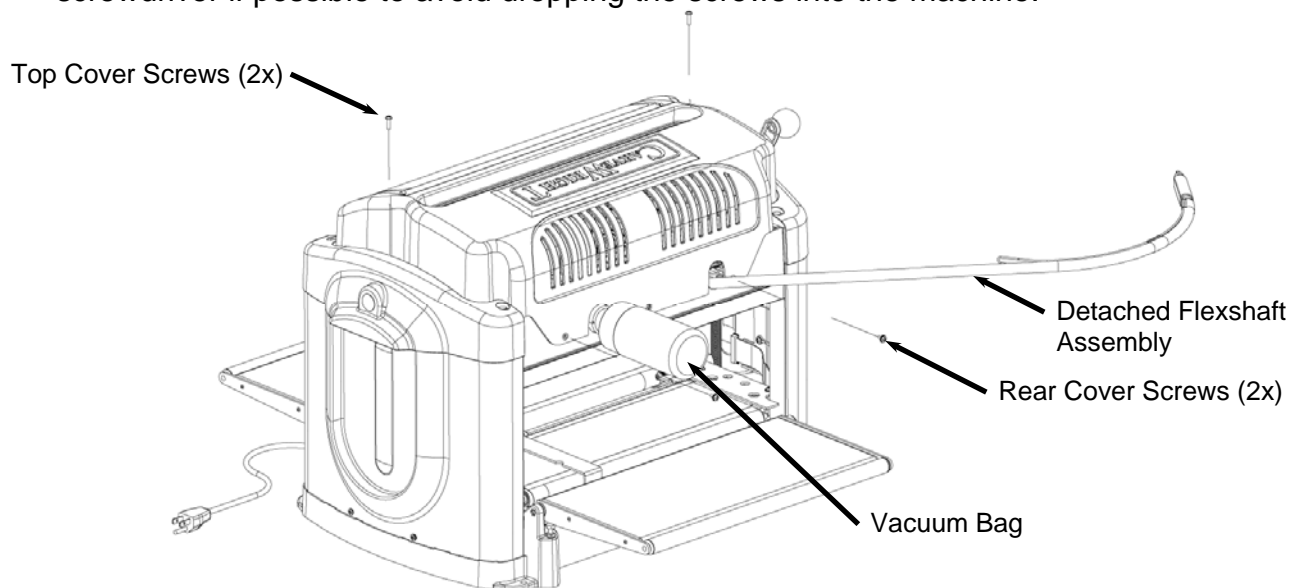
FIGURE 2: EXTERIOR VIEW OF THE FLEXSHAFT AND HEAD COVERS

3. **Detach the flexshaft from the top of the Z-truck:** The flexshaft assembly is retained by a ball detent located in the flexshaft receptacle (See Figure 3). Firmly grasp the flexshaft support tube while reaching under the clear front cover with your other hand to grab the Z-truck. Pull up firmly on the flexshaft support tube and twist slightly while bracing the Z-truck. **DO NOT PULL ON THE SHEATH.** The flexshaft will pop out of the detent. Wrap the end of the flexshaft in tape so that the core will not fall out and lay the detached flexshaft end to the side.



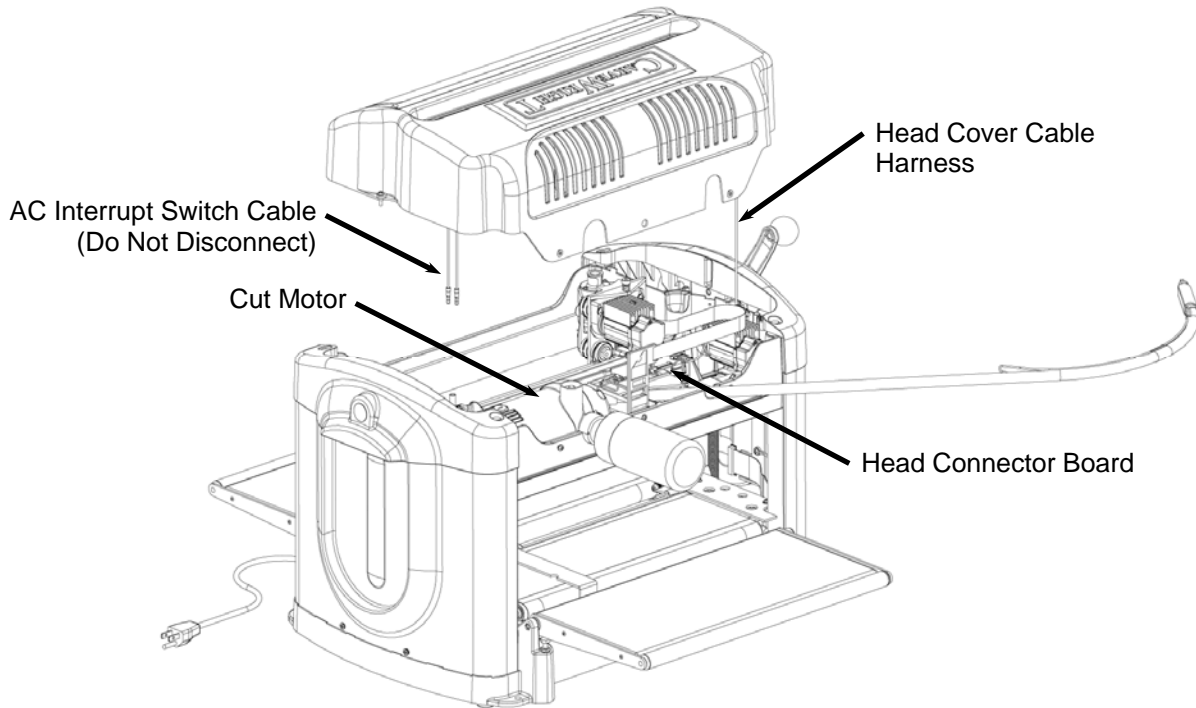
**FIGURE 3:** VIEW OF THE FLEXSHAFT CONNECTION TO THE Z-TRUCK

4. **Remove the screws securing the cover:** Remove the four cover screws as shown in Figure 4 with the #2 Phillips screwdriver. Use a magnetic tipped screwdriver if possible to avoid dropping the screws into the machine.



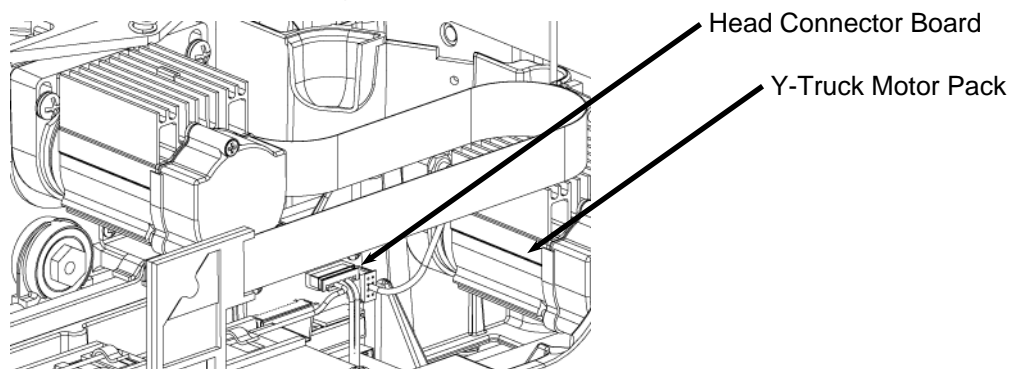
**FIGURE 4:** EXPLODED VIEW OF THE COVER SCREWS

5. **Detach the cover and locate the cover cables:** Lift the cover straight up and locate the two cables still connecting it to the head. On the side nearest the AC cut motor you will see the cable that connects the cover interrupt switch. For this repair we want to avoid disconnecting this cable if possible. If for some reason you have to disconnect this cable to entirely remove the head cover, you will need to locate and disconnect the two bullet connectors at the back of the AC motor. In most machines you will need to remove the screw in the small plastic enclosure to access the two bullet connectors. On the opposite side you will see the 8-wire head cover cable harness (terminated with a 10-pin connector).

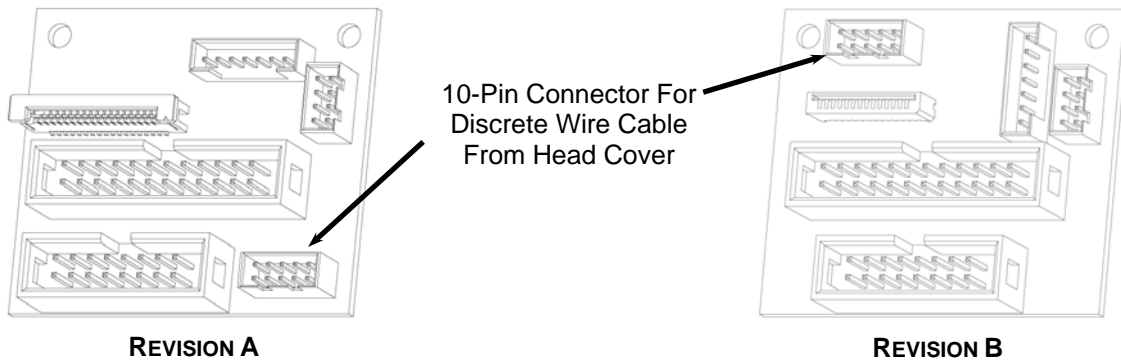


**FIGURE 5: EXPLODED VIEW OF THE LIFTED COVER**

6. **Unplug the head cover cable at the head connector board attached just to the left of the Y-drive motor pack.** The location of this connector on the connector board will vary depending on the machine's production date (See Figure 7). You may have to reach underneath the head to unplug the cable. Notice how the cable is routed along side and under the Y-truck motor pack. This routing is important to remember when re-assembling the cover.

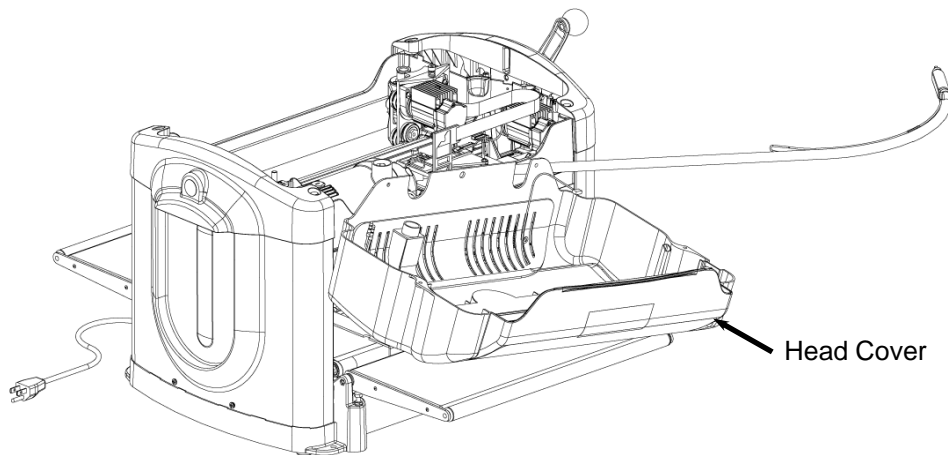


**FIGURE 6: LOCATING THE HEAD CONNECTOR BOARD**



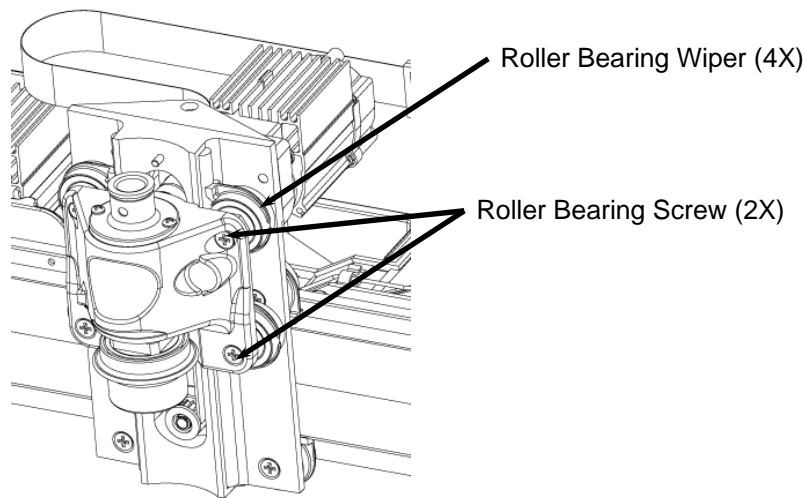
**FIGURE 7:** LOCATION OF CONNECTOR FOR HEAD COVER CABLE FOR THE EARLIER REVISION A AND LATER REVISION B MACHINES

7. **Lay the head cover to the side:** With the AC Interrupt Switch Cable still connected, carefully lay the cover onto the back outfeed tray (See Figure 8). Make sure to avoid pulling on the cable during the rest of the repair. You can also lay the cover over the side as shown in **Picture 1** of Appendix A.



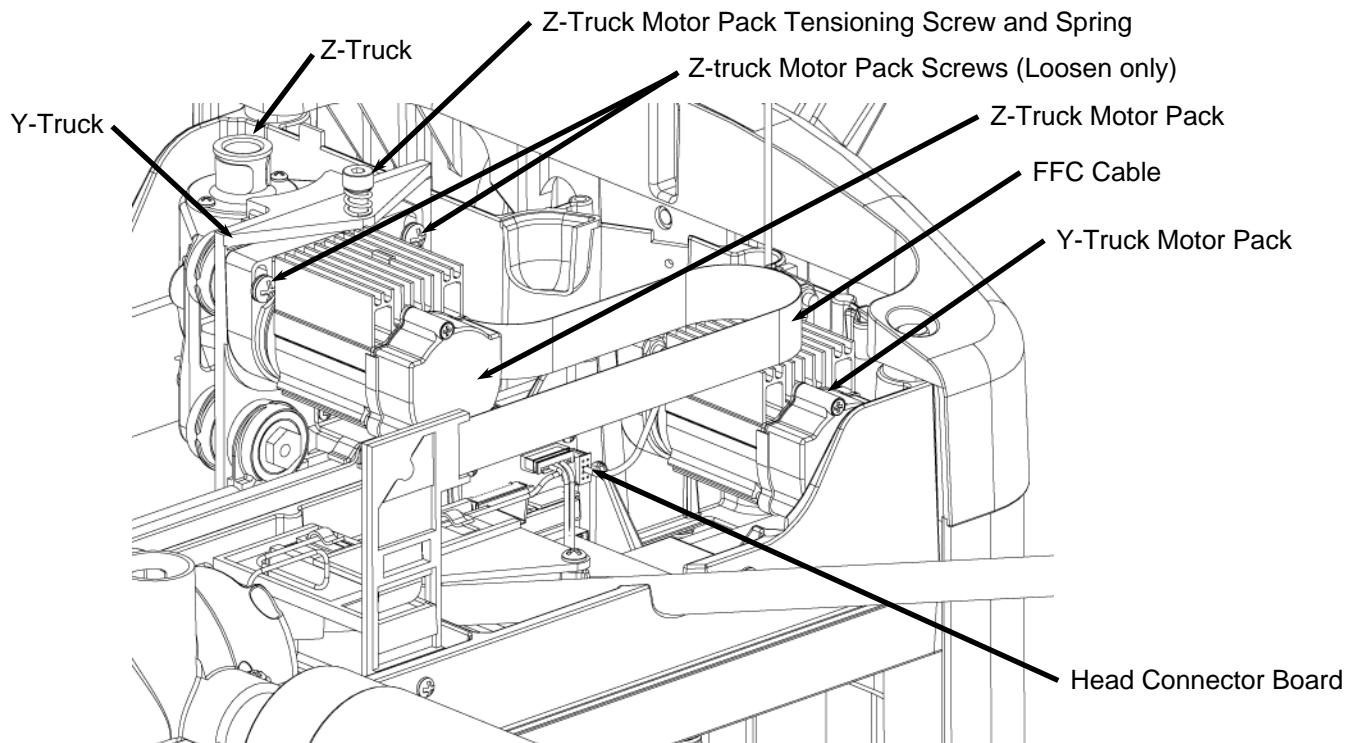
**FIGURE 8:** EXPLODED VIEW OF THE REMOVED COVER

8. **Remove the roller bearing wipers:** Remove all four of the roller bearing wipers on the Z-truck by simply pulling them off (See Figure 9). Also if your machine still has a Z-truck Flag, as in Figure 1, you may remove it permanently. It is no longer used or needed.
9. **Rotate the adjustable roller bearings:** To remove the Z-truck, the right side adjustable roller bearings will have to be rotated to clear the vertical rails (or in some cases entirely removed). Since permanent thread cement is used to secure the roller bearing screws we cannot simply unscrew them. Using the 12mm flat wrench rotate the roller bearing studs clockwise about half a turn so the truck can be pulled straight off of the Y-truck. If the rollers cannot be rotated with the wrench, the heads of the screws will have to be drilled out using a 3/16" drill bit. Before drilling make sure that you have placed a towel or other cover over the sandpaper belt trays. This cover will catch the metal shavings and will prevent them from contaminating the machine. Center the 3/16" drill bit on the center of the screw head and drill until the head of the screw comes loose. Repeat for both rollers.

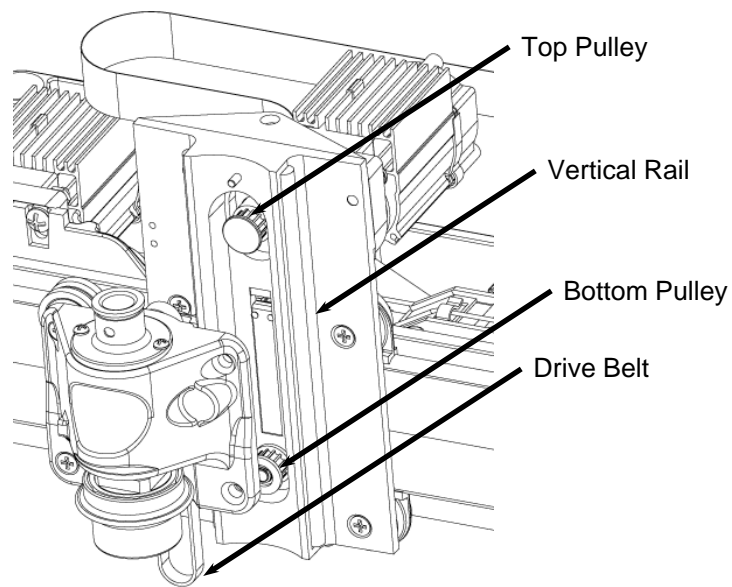


**FIGURE 9:** VIEW OF THE Z-TRUCK ROLLERS

10. **Loosen the Z-truck motor pack:** Once the cover is removed and the rollers are rotated, remove the Z-truck motor pack tensioning shoulder screw and spring with the 4mm Allen wrench. Then loosen the two screws holding the motor pack onto the Y-truck. **Do not fully remove these screws** because the motor pack will come loose and could possibly damage the white FFC cable that is still attached to it. Use extreme caution when working around this FFC cable as it is easily damaged.



**FIGURE 10:** CLOSE-UP VIEW OF THE HEAD ASSEMBLY



**FIGURE 11:** VIEW OF THE FREE Z-TRUCK

- 11. Remove Z-truck from machine:** Push the truck down to reveal the belt. Grab the belt and loop it over both pulleys. The Z-truck can now be removed. Note that the vertical rails are not attached to the structure and may fall out so be sure that you still have a cover over the sandpaper belts to avoid damage if they fall out of the slots.

## Reassembling the Z-truck

1. **Prepare the new Z-truck:** The Z-truck replacement will come as a unit along with two adjustable roller bearings and their screws. Before placing it back on the machine, place a small dab of permanent thread cement along the length of the screw threads and assemble the rollers to the main Z-truck assembly. Orient the rollers such that the hex stud on the roller bearing faces the truck. In this first step start the thread but do not tighten it. It is imperative that the thread cement be used on these screws or they will loosen quickly during operation.

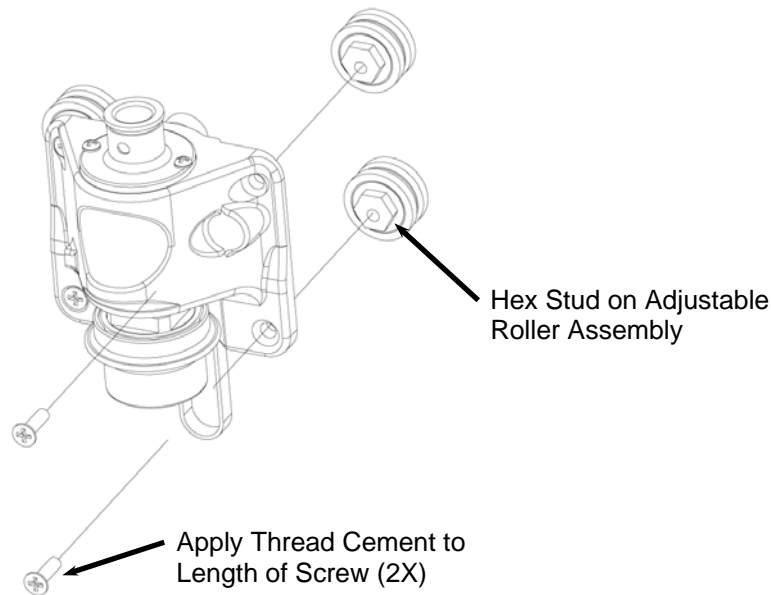
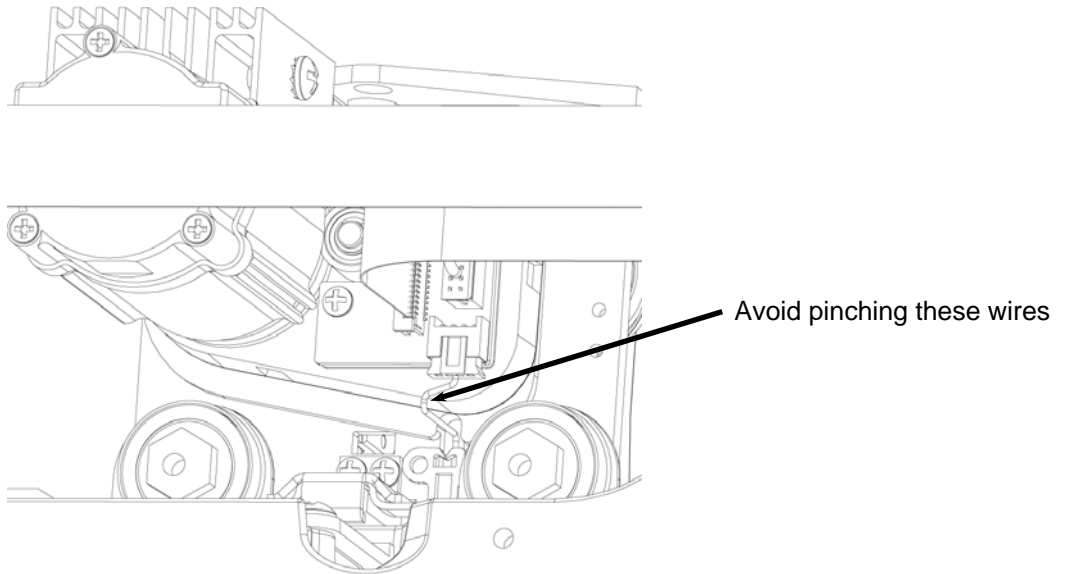


FIGURE 12: VIEW OF AN UNASSEMBLED Z-TRUCK

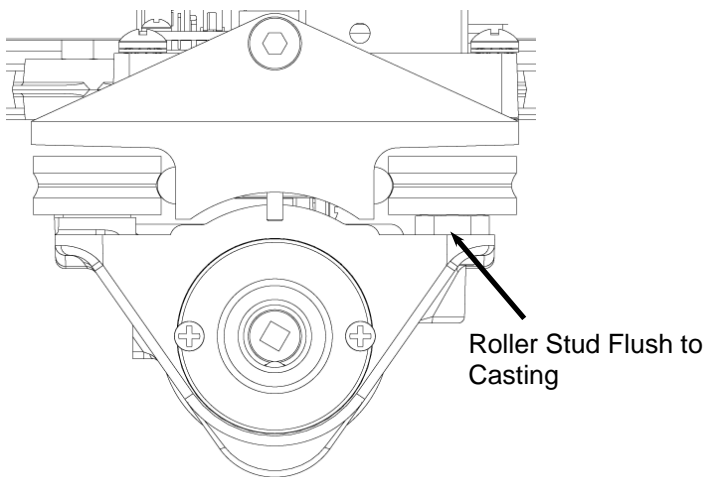
2. **Assemble the new Z-truck back onto the head:** Reassemble the new Z-truck with the loose rollers onto the rails. Loop the belt over both pulleys and slip the loose rollers over the vertical rails.
3. **Re-tension the Z-truck belt:** In order to keep the truck in place while you tighten it, replace the Z-truck motor pack tensioning shoulder screw and spring with the 4mm Allen wrench (See Figure 10). This screw and spring set the tension on the belt to the correct level. Tighten the shoulder screw all the way down.
4. **Tighten the two screws holding the Z-truck motor pack:** Tighten these two screws as tight as possible by hand. Check again and make sure that the Z-truck motor pack tensioning shoulder screw and spring are in place and tight before tightening these screws. Failing to tighten these screws after the Z-truck motor pack tensioning shoulder screw and spring will result in an incorrect belt tension. Also make sure that all wires are clear of the area. It is possible to pinch the wires coming up from the board sensor when this interface is tightened. Move the Z-truck

up and down its entire travel feeling for jerky or noisy motion. If the motion is not smooth the belt is not tensioned correctly or the motor pack gears may need to be adjusted.

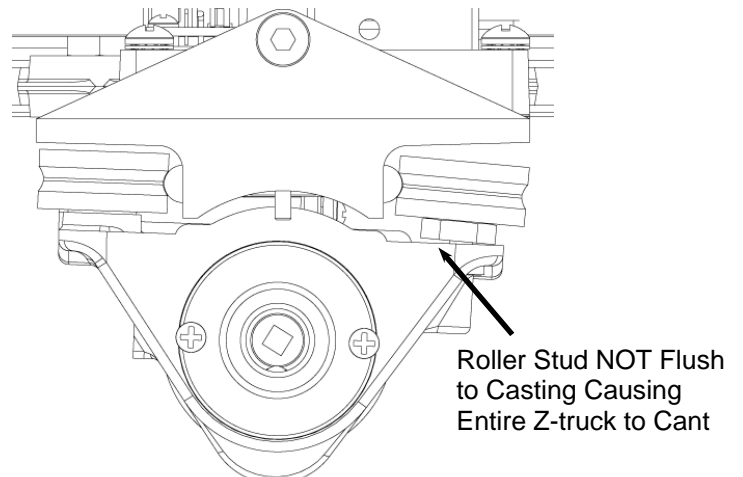


**FIGURE 13:** VIEW OF THE BACK OF THE Y-TRUCK

- 5. Tighten the adjustable roller bearings:** This is the most important step in the replacement process. First using the 12mm flat wrench to hold the roller stud, tighten the roller screw so that the face of the hex stud is snug against the back of the casting. Do this for both rollers but do not fully tighten the screws. The problem that must be avoided is creating a cant to the truck by not having the face of the roller stud flush with the Z-truck casting. See Figure 14 and 15 for a comparison of a properly and improperly assembled roller.

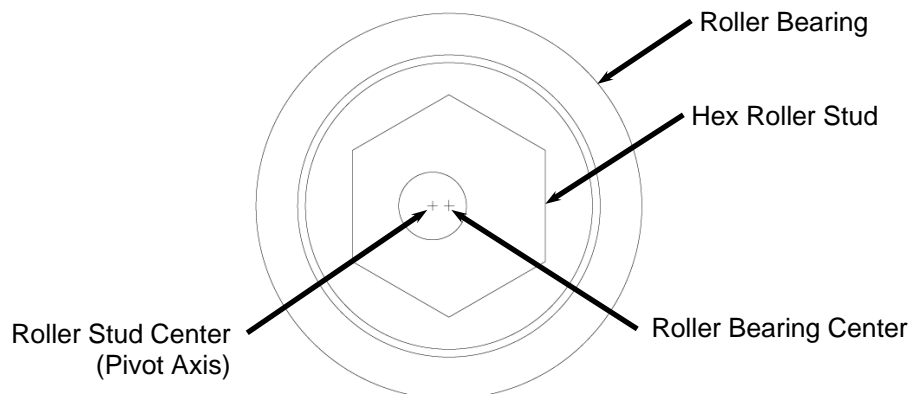


**FIGURE 14:** TOP VIEW OF A PROPERLY INSTALLED Z-TRUCK



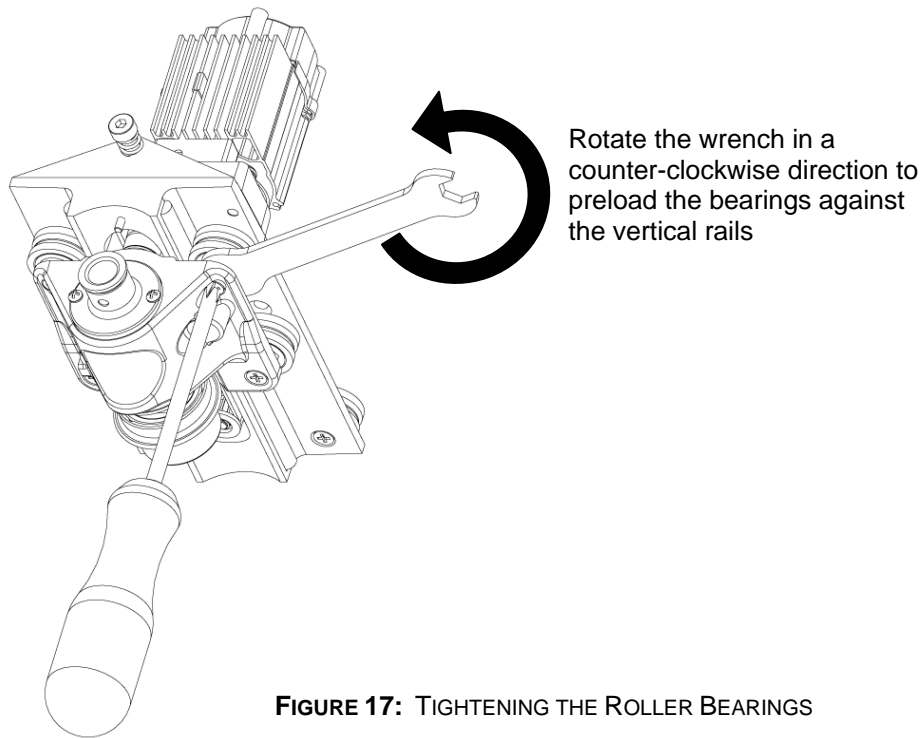
**FIGURE 15:** TOP VIEW OF A IMPROPERLY INSTALLED Z-TRUCK (CANTED)

6. **Preload the bearings against the vertical rails:** The adjustable roller studs are made such that the screw hole is off center of the central bearing axis. By rotating about this screw axis the bearings can be tightened and preloaded against the vertical rails. Once the rollers are tightened so that they are flush to the back of the casting we will use the flat wrench to preload them against the vertical rails.
  - a. Using the flat wrench, rotate the bearing roller counter-clockwise until the bearing contacts the vertical rod. Do not hold the screw in place while rotating the bearing for this step.
  - b. Once contact has been made rotate the wrench slightly clockwise in order to take all load off the bearing and vertical rail. They can still be touching but not loaded against each other.
  - c. Using the wrench to hold the stud in place hand tighten the screw with the screwdriver (do not tighten all the way yet).
  - d. After tightening check to see that the hex stud is still flush to the casting as in Figure 14.
  - e. Repeat steps a-d for second bearing.



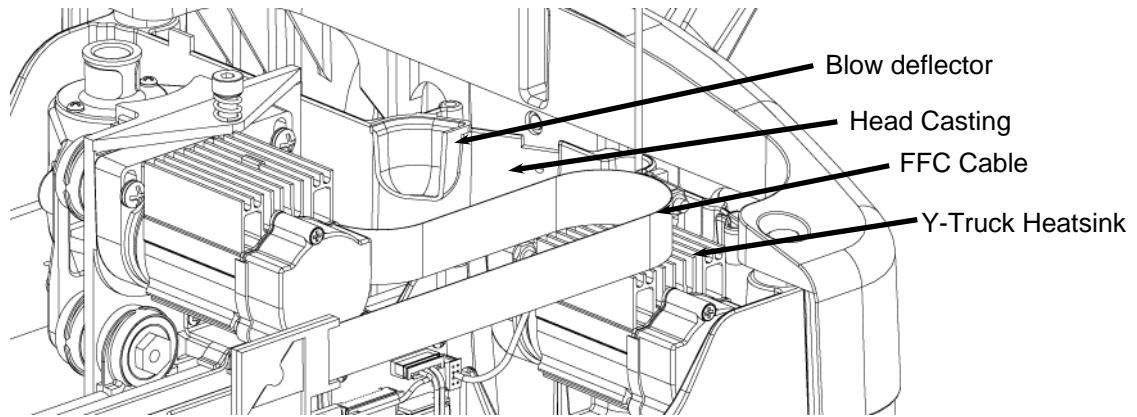
**FIGURE 16:** ROLLER BEARING AND ROLLER STUD

- f. Next, turn the wrench counter-clockwise while holding the screw in place. Alternate tightening each roller only slightly to balance the preloading. After each tightening check to see that the hex stud is still flush to the casting as in Figure 14. The proper preload level is reached when you can no longer rotate the bearing against the rail with your fingers. If it is too loose you will be able to have the bearing skate across the rail surface without the truck moving. Once the rollers have the correct preload hold the wrench still and tighten the screw as much as possible by hand.

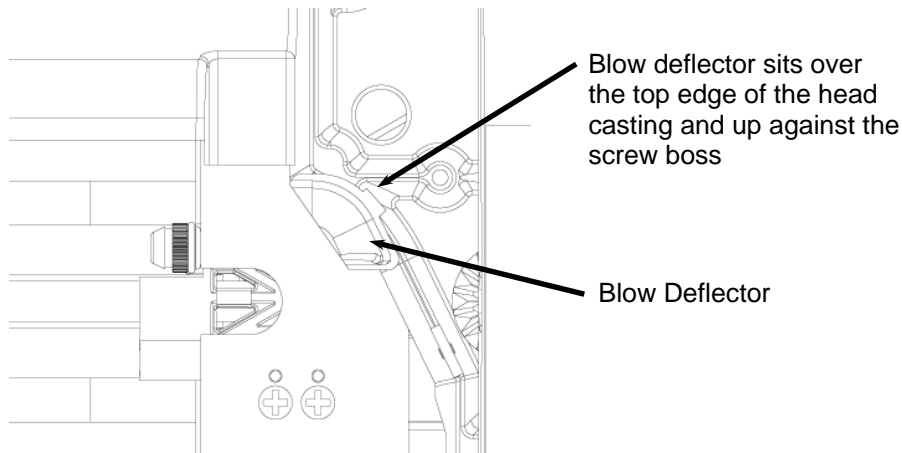


**FIGURE 17:** TIGHTENING THE ROLLER BEARINGS

7. **Test the assembled Z-truck:** Move the tightened Z-truck up and down along its entire travel range. The Z-truck should move smoothly and quietly along the rails. If the travel is jerky, stiff, or otherwise not smooth you may want to retry the roller-tightening step. If noises are heard coming from the assembly you may loosen it again and test the travel without the bearing tight. This may indicate whether the motor pack needs adjustment.
8. **Replace the roller bearing wipers:** Snap all four of the bearing wipers onto the roller bearings. Make sure that they snap snugly around the circumference of the bearing and sit flat on the vertical roller rods.
9. **Replace the head cover.** There are several important steps and checks needed as you replace the head cover.
  - a. Move the Y-truck all the way to the left side of the machine and make sure that the FFC cable does not drag on the Y-truck heatsink (See Figure 18). If the FFC cable is dragging bend it upwards so that it consistently clears the heatsink.
  - b. Make sure that the blow deflector is correctly placed. If it is out of place the board sensor can quickly become covered in dust and inoperable and/or the Z-truck will hit the blow deflector and stall. The deflector sits over the edge of the head casting and lines up with the air tube in the cover when assembled. Also see **Picture 2** in Appendix A.

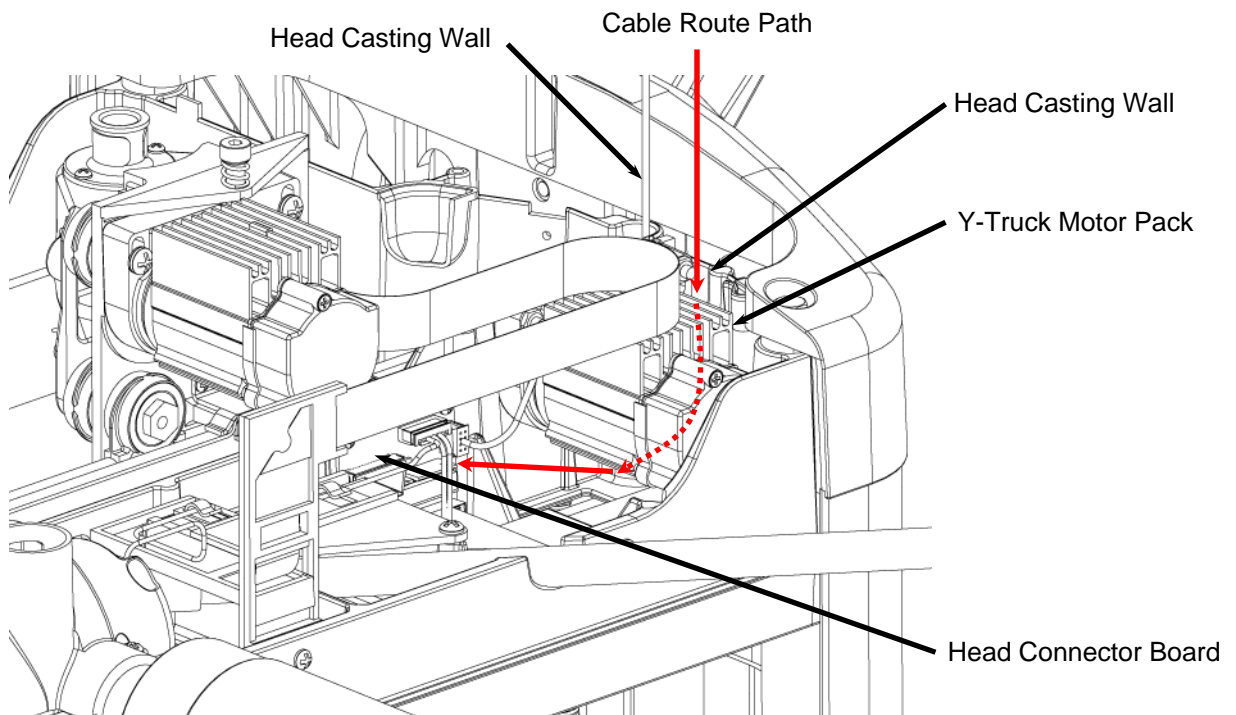


**FIGURE 18:** PLACEMENT OF THE BLOW DEFLECTOR - ISO



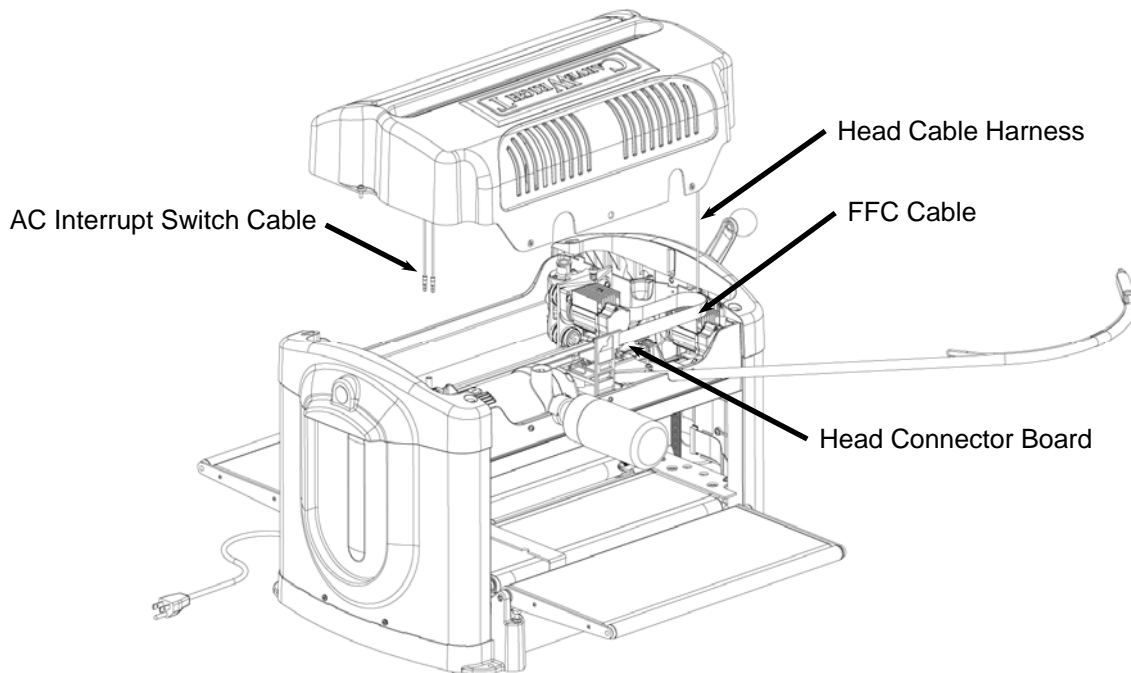
**FIGURE 19:** PLACEMENT OF THE BLOW DEFLECTOR - TOP

- c. Route the Head Cable Harness down between the wall of the head casting and the side of the Y-motor pack, under the Y-motor pack and plug it into the connector board as shown in Figure 20. Make sure that the connector is oriented correctly using the keying ribs and slots before plugging it in. Note that the white wire will be oriented toward the non-keypad side of the machine.



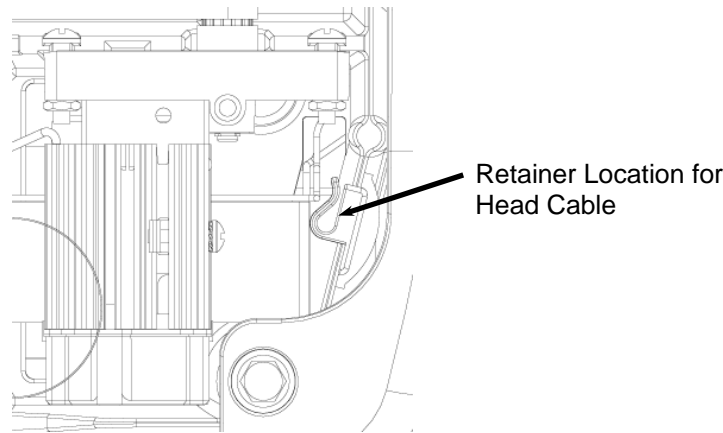
**FIGURE 20: ROUTING THE HEAD CABLE HARNESS**

- d. Gently lift and replace the head cover onto the head making sure that the FFC cable, the AC Interrupt Switch Cable, and the Head Cable Harness are not pinched.



**FIGURE 21: RESEATING THE HEAD COVER**

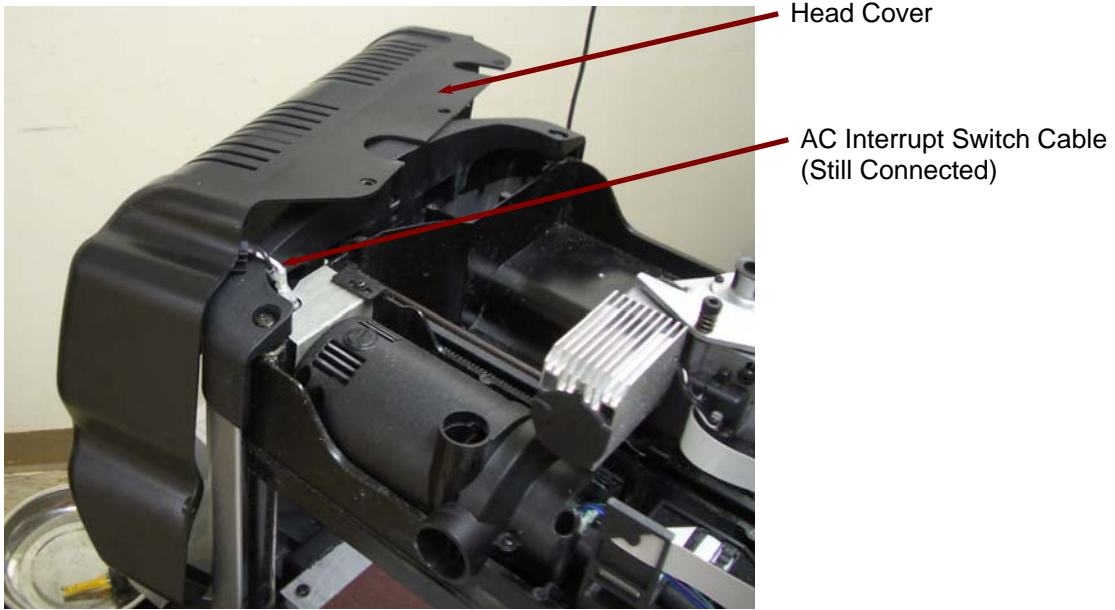
- e. Once the head cover is placed back onto the head you will need to reseal the wire harness retainers in the correct locations before replacing the screws. These retainers should be attached to the cables themselves and keep the cables confined to certain areas. In some machines there will be one on both cables, but on most machines you will only find one on the Head Cable Harness. You will have to reach in from the front of the machine to access them. Make sure that the retainers are placed over the edge of the head casting and under the edge of the cover. Make sure that they do not prevent the head cover from setting flat. See **Picture 3** and **Picture 4** in Appendix A for further clarification.



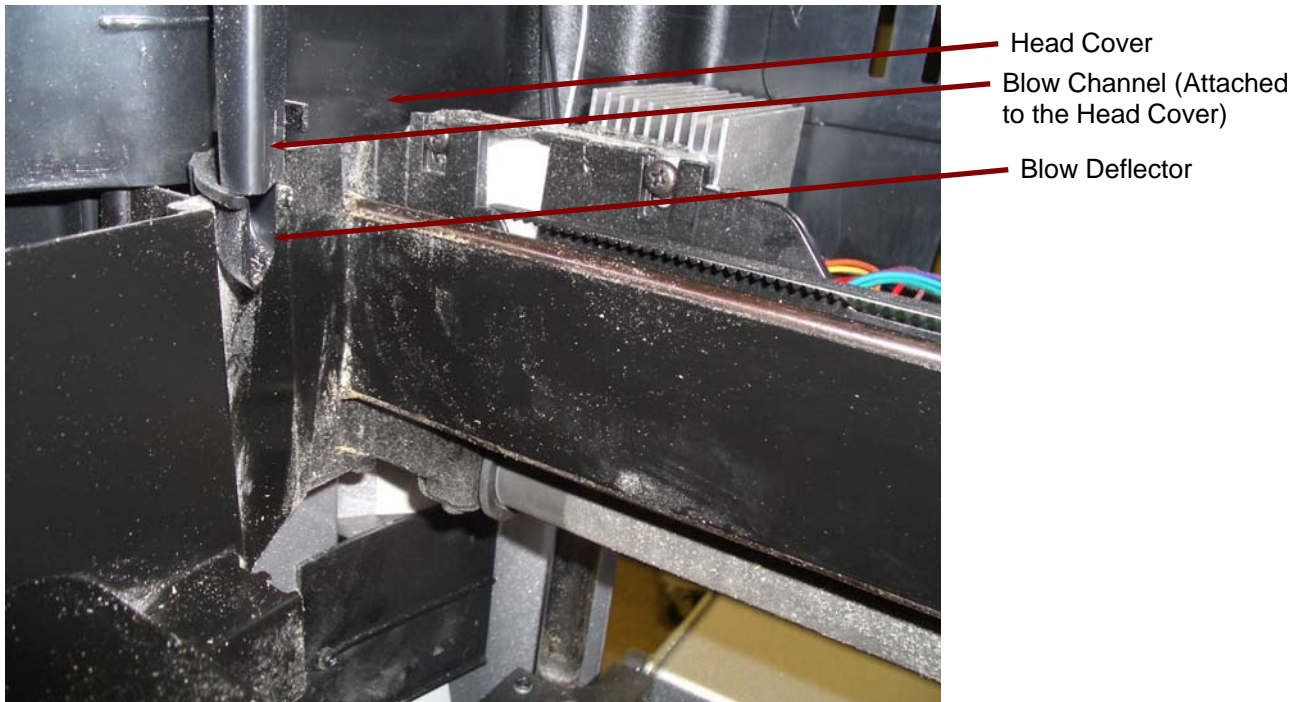
**FIGURE 22:** LOCATING THE HEAD CABLE HARNESS RETAINER

- f. Replace the four screws as shown in Figure 4. The two long screws go in the vertical locations.
  - g. Verify that the head cover is laying flat on the head. Verify that the blow deflector is lined up with the vertical blow port located in the head. Verify that the FFC cable does not drag on the Y-motor heatsink when the Z-truck is pushed all the way to the left hand side.
- 10. Prepare the flexshaft assembly for re-insertion into the machine:** Gently pull the protruding flexshaft core (with squared end) out of the sheath several inches. Push the core back into the sheath and make sure that it slips into, and engages, the cutting motor. It will drop into the receptacle on the motor side about 5/8ths of an inch. Turn the core by hand and feel for resistance of the motor. If the shaft spins without resistance, push the core inward while rotating until it drops into the slot and engages the motor.
- 11. Insert the flexshaft into cutting head:** Looking through the slot in the top cover, locate the flexshaft receptacle on the top of the Z-truck. Inside the receptacle there is a square recess that mates with the exposed square end of the flexshaft core. Turn the chuck on the bottom of the cutting head (open the safety cover for access) until the square core end can be inserted into the recess. Press the flex shaft all the way down into its receptacle. A click will be heard and felt as the shaft snaps into place.

## Appendix A



**PICTURE 1:** LAYING THE HEAD COVER OVER THE SIDE OF THE MACHINE

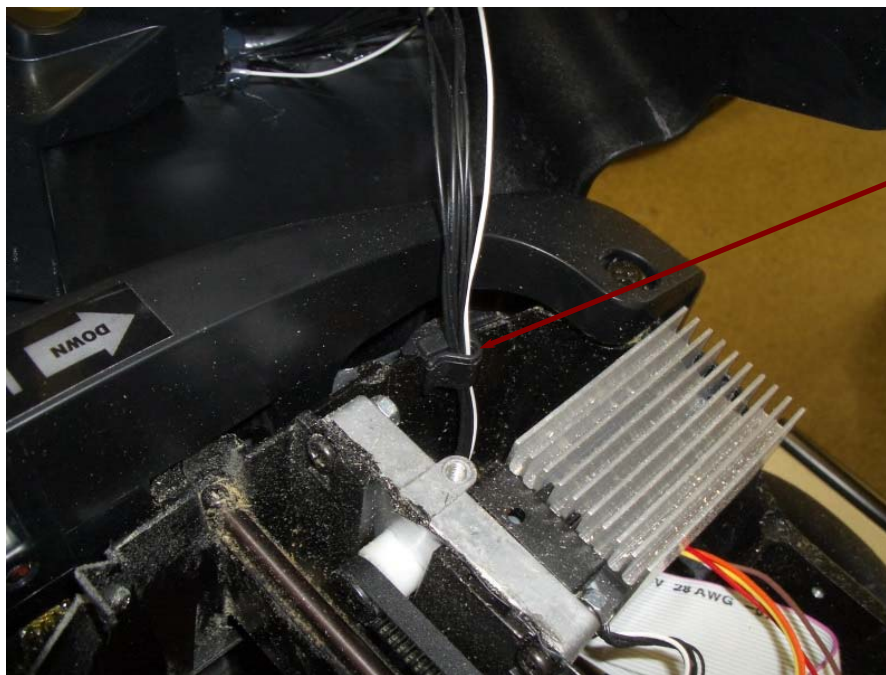


**PICTURE 2:** LOCATION OF THE BLOW DEFLECTOR



Wire Retainer  
(AC Motor Side)

**PICTURE 3:** LOCATION OF AC INTERRUPT SWITCH CABLE WIRE RETAINER



Wire Retainer

**PICTURE 4:** LOCATION OF HEAD CABLE HARNESS WIRE RETAINER