

Operator's Manual

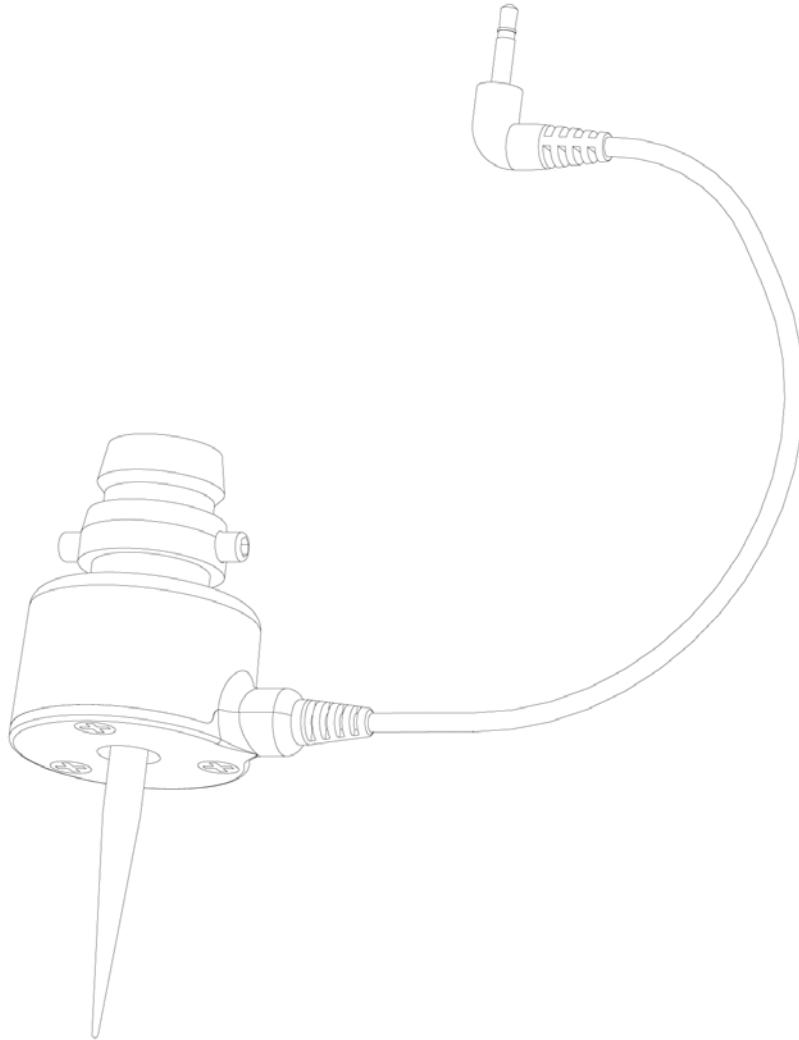

3-D Scanning Probe



Please save this manual for future reference.

CAUTION: Read and follow all Safety Rules and Operating Instructions before using this product.

- **Warranty**
- **Safety**
- **Features**
- **Setup**
- **Operation**

LHR Technologies Inc., Pasadena, Texas 77502

Introduction

The CarveWright™ Scanning Probe Accessory will open up a whole new world of possibilities for CarveWright System users. The scanning probe will enable height mapping of existing surfaces and objects that can then be imported into the CarveWright Design Software libraries for use on any project. This manual will explain the many features of the CarveWright Scanning Probe to help make the scanning functionality easy to understand and rewarding to use.

For access to online information about the CarveWright Design Software visit <http://www.carverwright.com>.



WARNING or CAUTION:

Look for this symbol to point out important safety precautions. It means attention -- Personal safety is involved!



Look for this symbol to point out helpful information and hints that will allow maximum efficiency and enjoyment of the CarveWright Scanning Probe.

CARVEWRIGHT SIX MONTH LIMITED WARRANTY

If this product fails due to a defect in material or workmanship within six months from the date of purchase, return it to CarveWright for free replacement.

This warranty gives you specific legal rights, and you may also have other rights, which vary from state to state.

LHR Technologies Inc., Pasadena, Texas 77502

Table of Contents

INTRODUCTION.....I

TABLE OF CONTENTS II

SPECIFICATIONS..... 3

UNPACKING THE SCANNING PROBE 3

SAFETY PRECAUTIONS..... 3

MACHINE AND PROBE CONFIGURATION 4

SCANNING PROBE INSTALLATION..... 6

PLACING OBJECT ON A SCANNING SLED 7

INSERTING THE SCANNING SLED..... 8

JOGGING THE SCANNING PROBE 10

SETTING THE SCAN AREA 10

SETTING THE SCAN OPTIONS 11

ACCESSING THE SCAN DATA 12

GENERAL TIPS AND HELPFUL REMINDERS..... 13

Specifications

Scanning Resolution.....	0.005”
Scanning Step Size:	
Best Mode.....	0.010”
Normal Mode.....	0.020”
Draft Mode.....	0.040”

Unpacking the Scanning Probe

The scanning probe will come packaged with the following:

- A) 3-D Scanning Probe mounted in Quick Change adapter
- B) CarveWright Scanning Software CD
- C) Operators Manual

Safety Precautions

General Safety Rules For Using the CarveWright



ALWAYS BE ALERT. Operating electrically powered machinery poses a risk of serious physical injury to hands and fingers. Always operate machinery with **ALL** guards in place and in good working order. **DO NOT** attempt to defeat safety guards!

- **KNOW THE POWER TOOL.** Read the CarveWright operator's manual carefully. Learn the machine's applications and limitations as well as any specific potential hazards related to this tool.
- **DISCONNECT the CarveWright** from the outlet when not in use or before servicing.
- **GUARD AGAINST ELECTRICAL SHOCK** by preventing body contact with grounded surfaces such as pipes, radiators, or appliances while operating.
- **DO NOT OPERATE ANY POWER TOOL WHILE UNDER THE INFLUENCE OF DRUGS, ALCOHOL, OR ANY MEDICATION AFFECTING ALERTNESS.**
- **STAY ALERT AND EXERCISE CONTROL.** Stay alert and use common sense. Do not operate the tool when tired. Do not rush.
- **BE SURE THE SCANNING PROBE CLEARS THE WORKPIECE.** Never start the system with the probe tip touching the work piece.
- **NEVER ATTEMPT TO DEFEAT SAFTY DEVICES OR INTERLOCKS.** Guards and other safety devices protect the user from injury; do not try to bypass or remove them.
- **DO NOT PLACE HANDS ON THE GRIT SURFACE DRIVE BELTS DURING OPERATION.** Belts in motion could drag a hand into the machine and cause injury.
- **USE A SUPPORT FOR LONG WORKPIECES.** To minimize the risk of over stressing the machine, use a sturdy “outrigger” support when scanning long workpieces more than 36 inches in length. Never substitute a person for a proper support.

Machine and Probe Configuration

The key components of the CarveWright System and Scanning Probe are shown in the following illustration.

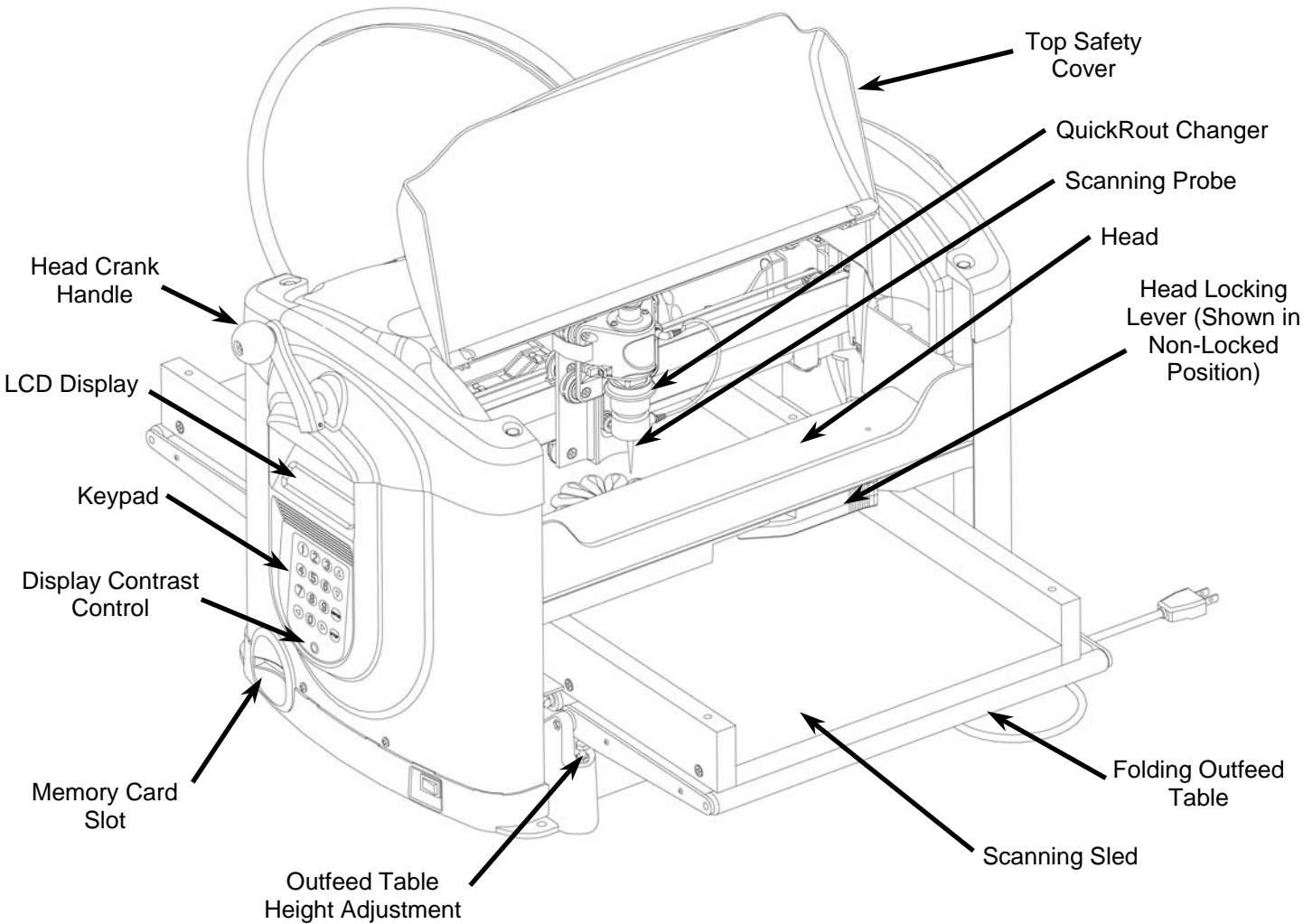

FIGURE 1: CARVEWRIGHT AND SCANNING PROBE CONFIGURATION

It is helpful to review and understand the directional conventions for the CarveWright machine when working with the scanning probe. Please refer to Figure 2. This manual will refer to these conventions throughout.

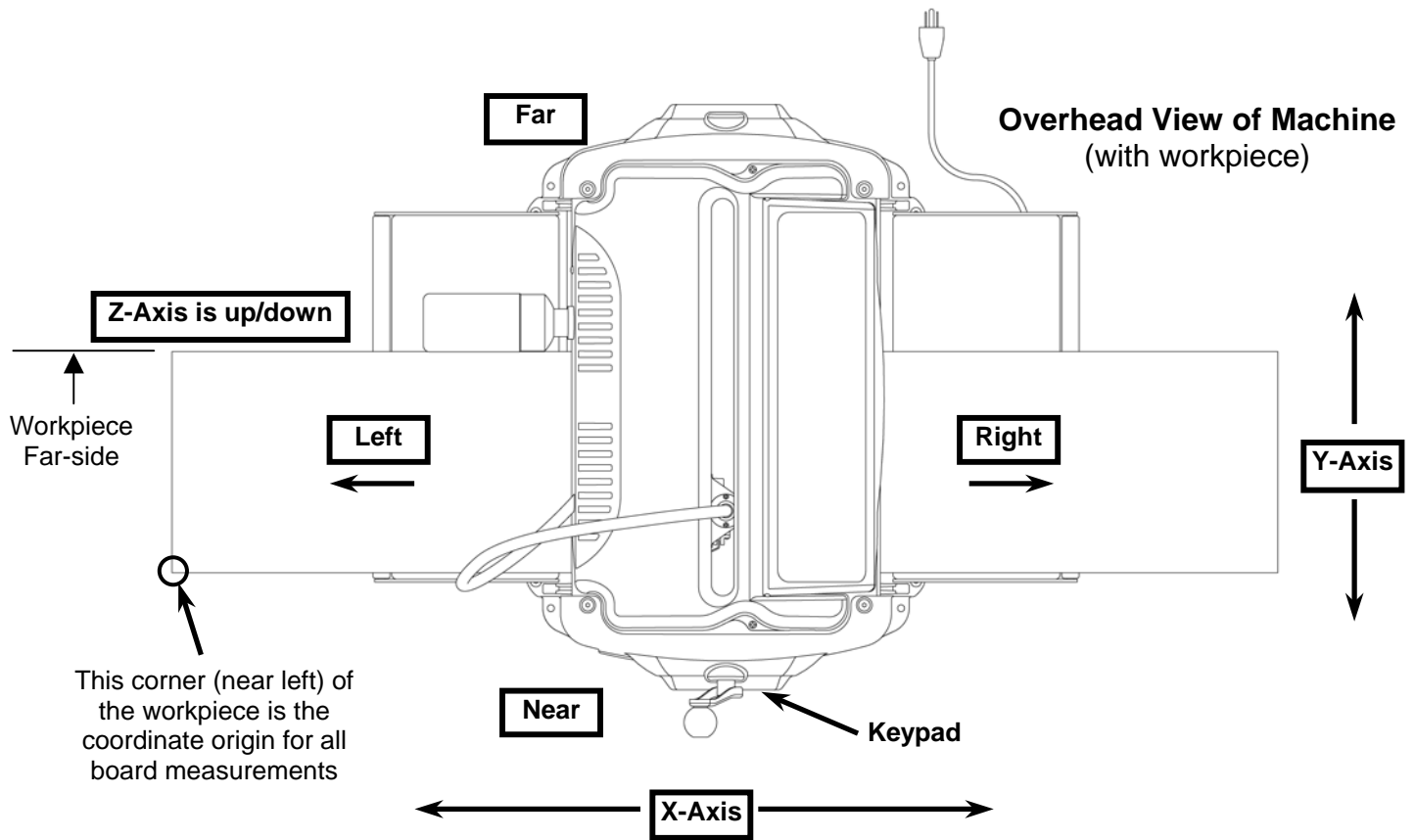

FIGURE 2: CARVEWRIGHT DIRECTIONAL CONVENTIONS

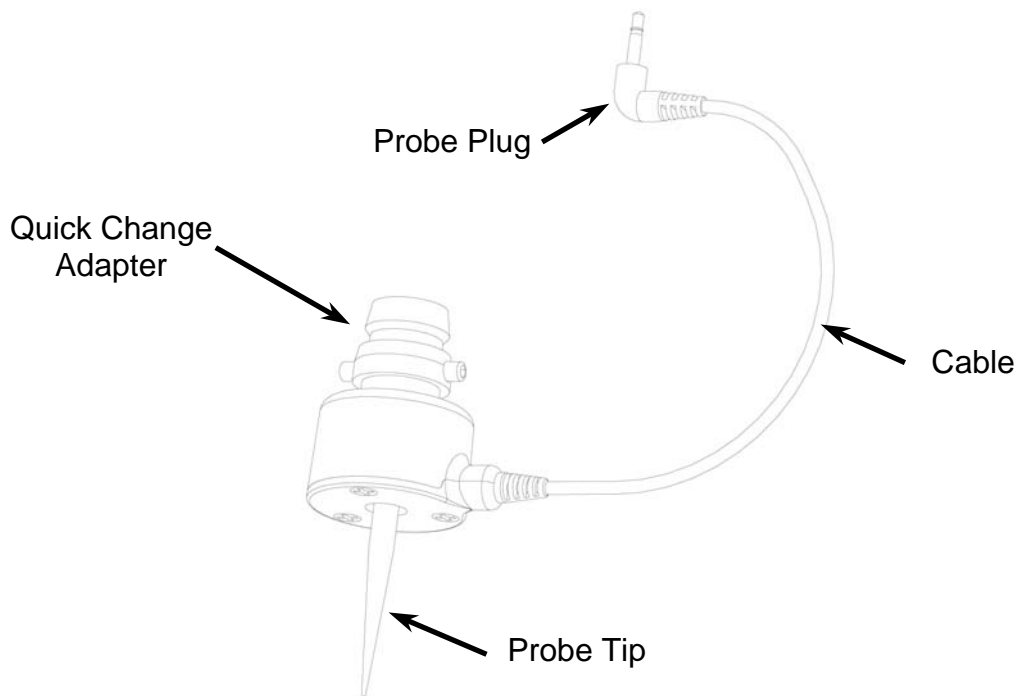

FIGURE 3: SCANNING PROBE FEATURES

Scanning Probe Installation

The scanning probe uses the same QuickRout quick-change system for installation that all CarveWright bits use. Before installing the scanning probe into the CarveWright, lift up the front safety cover and make sure that there are no other bits installed. Next, make sure that the quick release chuck is cocked and ready to accept the adapter mounted to the probe.

To cock the chuck, place a thumb on the Z-Truck Grip Ridge and two fingers on the Chuck Release Flange. Press up on the chuck release flange as far as possible and release (See Figure 4). The flange will snap and stay up when the chuck is prepared to receive the probe assembly. Any time difficulty is encountered inserting the probe simply pull up on the flange to insure the chuck is cocked. Press the probe assembly into the chuck until a slight snap is felt. The probe is now secure in the quick change

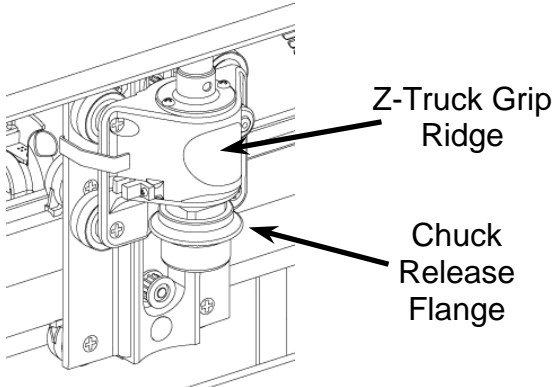

FIGURE 4: QUICK RELEASE CHUCK FEATURES

Insert the probe plug into the jack located on the Z-Truck. If the probe is correctly installed the CarveWright machine will recognize it when the cover is closed and power is turned on. The scanning functionality can now be accessed through the keypad.

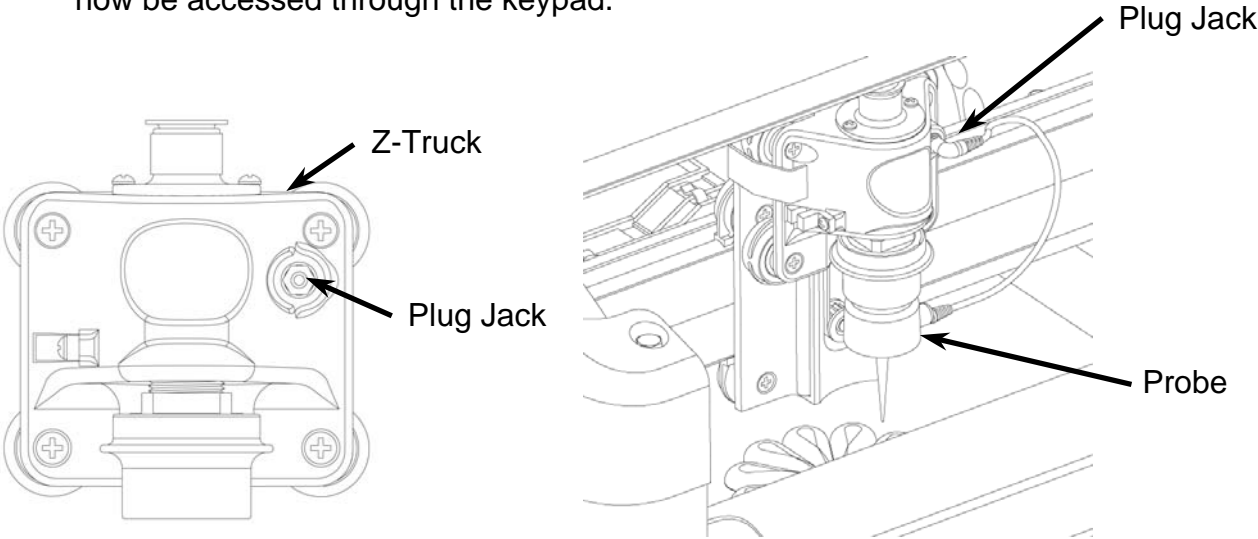

FIGURE 5: PLUGGING IN THE PROBE



All motors are disabled whenever the cover is open. The cover must be closed before the machine can proceed.

Placing Object on a Scanning Sled

Because most objects that will be scanned are not suitable for scanning directly they will have to be placed onto a fixture called a scanning sled before proceeding (not included with purchase). The scanning sled is designed so that the CarveWright can easily feed it through the machine and so that the scanning probe has the proper clearances to function.



Please contact CarveWright (www.carverwright.com) to purchase scanning sled or request a set of plans to make your own.

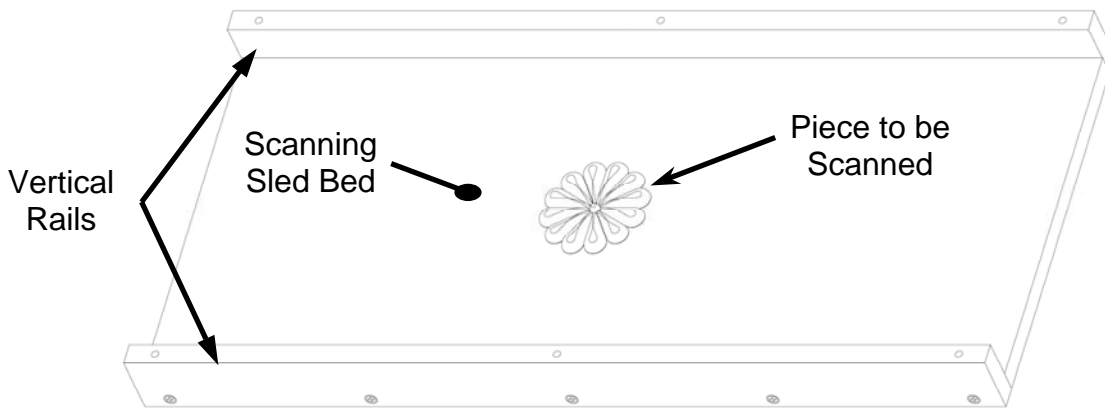

FIGURE 6: SCANNING SLED

The dimensions of the sled can vary but the maximum width is 14.5" and the maximum depth is 2-1/4" from the mounting surface to the top of the rails. There is no maximum length but any sled over 3 feet long will require additional stand-alone outfeed support rollers. The support rollers should be adjusted properly to avoid letting the sled sag or rise, as any transition going on and off the rollers will be reflected in the scan data. The vertical rails must be at least as high as the object being scanned. If the object is taller than the vertical rails the machine or object can be damaged.

The maximum height that the scanner body can clear is 1 inch. If the object to be scanned is taller than 1 inch in any location, check for possible interferences between it and the probe body. Interference is possible if there is a 1 inch tall point in the object within 1 inch of a portion of the object that lies at a depth near the mounting surface.

The scan object can be mounted to the sled with any number of adhesives. Hot glue works well as does double sided tape. It is important that the scan object be rigidly mounted. Any movement during scanning will produce poor scan data. It is also suggested that the mounting surface of the sled be very smooth and hard (like Formica). This hard surface makes mounting and removing the scan objects quick and easy.

The CarveWright will require that the sled be kept under rollers at all times so make sure that the object being scanned is at least 3.5 inches from

either end of the sled. The scan object must also be at least 1 inch from either vertical rail to clear the body of the probe.



Adding a grid pattern to the mounting surface of the sled surface makes positioning the scan object very easy.

Inserting the Scanning Sled

For the purposes of this manual we will assume that all pieces being scanned will be mounted to a scanning sled. Proper installation of the scanning sled is critical to the performance and continued operation of the scanning probe. To properly insert the sled:

1. Press down on the sliding guide plate release lever and move the sliding guide plate to the right so that it will clear the width of the sled.
2. Check the bottom of the sled for features that will make it unusable in the machine. The bottom surface of the sled where it contacts the squaring plate must be flat and level for a width of at least $\frac{3}{8}$ inches along the bottom edge to allow the Board Tracking Sensor to accurately calculate the position of the workpiece at all times (see Figure 7).
3. Lay the sled on the traction drive so that it is centered lengthwise under the head.
4. Push the sled firmly up against the squaring plate.

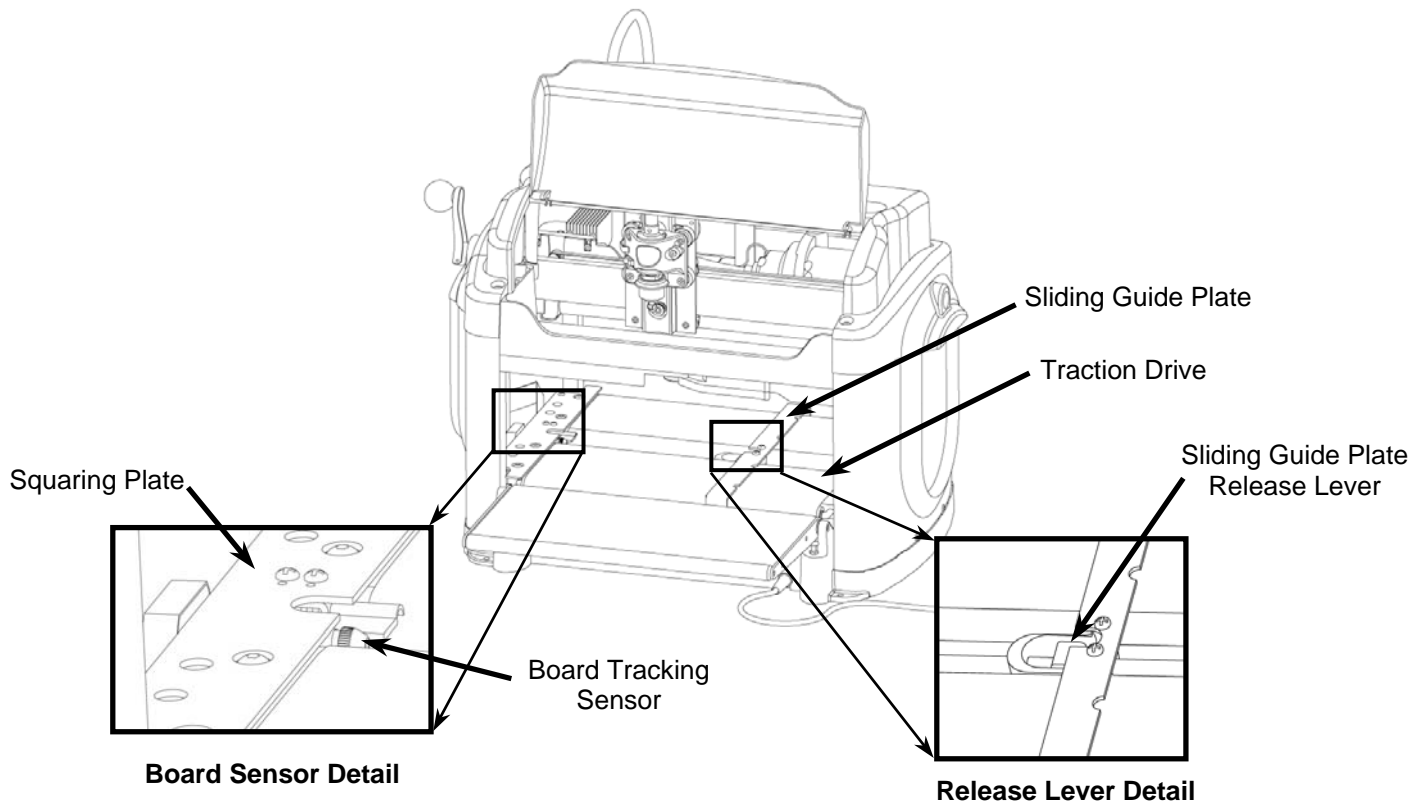

FIGURE 7: SCANNING SLED
INSERTION DETAILS

5. Gently push the sliding plate up against the inside edge of the sled. **DO NOT** push the sliding plate against the sled with significant force. The sliding plate is used to guide the sled and is not intended to lock the piece in position.
6. At this point it is critical that you assure that the sled can travel freely in and out of the machine along its entire length without binding or encountering significant drag. Do this by moving the sled in and out of the machine by hand, while laying flat on the traction drive.



WARNING: Do not attempt to load a sled that varies in height by more than 1/16" along its entire length. This condition could bind the machine and damage the traction drive.



WARNING: Do not attempt to load a sled that does not have parallel sides. This condition can bind the machine and damage the traction drive.

7. Lower the head by turning the head crank handle counter-clockwise until the clutch clicks several times (at least 5 clicks recommended). The clutch is intended to load the sled against the traction drive with consistent force.
8. Rotate the head-locking lever outward into the locked position. The sled is now secure.
9. Make sure that the top safety cover is closed before proceeding.

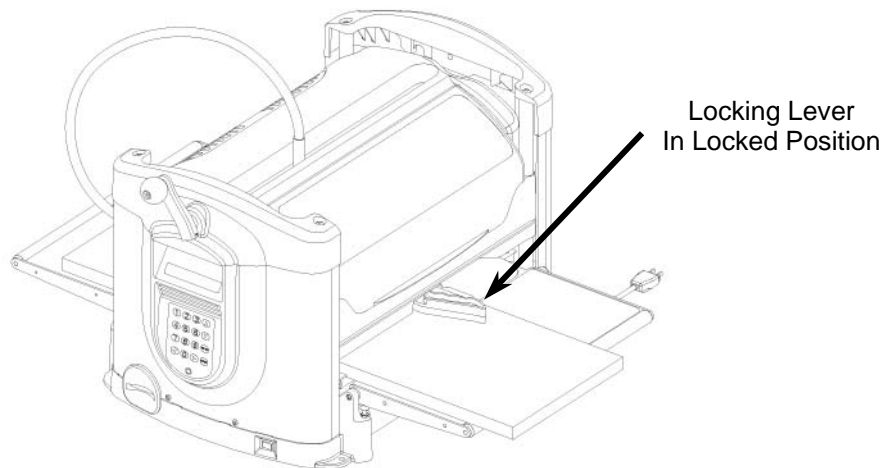

FIGURE 8: LOCKING LEVER CONFIGURATION

Jogging the Scanning Probe

Before the CarveWright can begin to function, the CarveWright memory card must be installed. With the power off, push the memory card gently into the memory card slot until it stops, making sure the label is up. Once the sled is installed and the cover is closed, proceed to turn the machine on.

At this point, control is accessed through the Keypad and LCD Display. The scan utility will automatically sense the scanning probe and will display the #6 (Accessory) menu. Select the *Scan Area* menu item.



FIGURE 9: CARVEWRIGHT
INPUT KEYPAD

Setting the Scan Area

When the *Scan Area* item has been selected from the display menu, the CarveWright will send the head to the home position. The display will then prompt for the user to specify the starting corner of the scan area.

The scan area is determined by specifying any two diagonal corners of the scan object. The user will need to jog the probe tip to the first corner point using the arrow keys. This is accomplished using the **up and down arrows** on the keypad to move the truck across the width of the sled (near to far), and the **left and right arrows** to move the sled along its length (left or right).



Holding an arrow key down results in a fast movement. Precise final positioning is accomplished using short bumps on the key.

Once the probe tip has been jogged to the desired corner location press **ENTER**. The probe tip will now slowly lower until the tip touches the surface. Verify that this is the correct location and press **ENTER** again. You can continue to tweak the tip location if it is desired before pressing **ENTER**. Repeat these steps for specifying the second corner.

Setting the Scan Options

Once both corners have been specified the display will show the *Scan Options* menu. The current scan quality will be shown in parentheses. The *Scan Options* menu has three options: 1) Proceed with Scan, 2) Change Quality, and 3) Set Max Depth.

If you wish to continue with the scan at this point select option one, *Proceed with Scan*. If you wish to change the quality setting select option two, *Change Quality*. Use the **up/down arrow** keys to find the desired quality and select **ENTER** to confirm. These quality modes affect the step size for each point measurement taken. The higher the quality mode selected, the smaller the step size. The *Best* setting step size is .010", the *Normal* setting step size is .020" and the *Draft* setting step size is .040". It is recommended that scans be performed at the highest possible quality setting if time permits.



The machine will check the memory card to verify that there is enough space to store all of the scan information. An empty memory card can hold approximately 2.2 ft² of **Best** quality mode scan data. If the message *Scan Too Large For Card* appears on the display then there is not enough room to store the proposed scan. Options to correct this situation are to reduce the size of the scan area or delete existing information on the card using the Flash Manager in the CarveWright Design Software.

After the quality mode has been confirmed the CarveWright display will show the *Scan Option* menu again. There are instances where the maximum depth of the scan will need to be limited. For example, in some areas the object being scanned may be deeper than the length of the scanning probe, which can cause the body of the scanner to impact the object and stall the scan. The *Set Max Depth* option allows the user to put a floor on the depth that the probe tip will reach. The procedure for setting the max depth works very similar to setting the corners of the scan area. Identify the desired max depth on the scan object surface. Jog the probe tip to a point directly over this location and press **ENTER**. At the chosen location the probe will lower until it makes contact with the surface. By default this depth will now be the maximum scan depth. If this depth is acceptable select **ENTER** otherwise reposition the probe tip and repeat. Once a max depth has been confirmed the display will prompt the user to *Use Selected Depth* or *Apply Offset*. If the *Apply Offset* option item is chosen, the user is prompted to input a numeric offset using the keypad. Select **ENTER** to proceed or **STOP** to cancel the offset. The entered offset will be added to the already confirmed max depth.

Once the desired settings have been set, proceed with the scan by selecting *Proceed with Scan*. The CarveWright will begin to scan the object. The scanning probe tip will follow along the object contour, mapping the 3-D coordinates of the surface as it proceeds. The height map information is stored onto the memory card for future retrieval by the

scanning software. A real time scanning completion estimator will be displayed on the LCD and provides an estimate of how much of the current scan is completed.



At any point during operation the CarveWright machine can be stopped by pressing the **STOP** key or by lifting the cover. If desired the machine can be restarted by closing the cover and pressing **ENTER**. The machine will resume scanning at the point where it was stopped. If you press the stop button a second time the scan will be aborted so be careful when restarting your project.











WARNING: Never remove the memory card from the machine while it is on. Doing so can result in damage to the workpiece.

Accessing the Scan Data

When the scan is completed the LCD Display will show a prompt to set another scan area. If you do not wish to produce another scan, turn off the machine, lift the top safety cover, release the head lockdown lever, and crank the head up to free the sled. The sled can then be removed. Remove the CarveWright memory card and place it into the CarveWright memory card programmer. Open the CarveWright Design software and access the scan data by selecting the *Download Scan* menu item on the *File* menu.

General Tips and Helpful Reminders

-  **MAXIMUM SCANNING DEPTH** is 1.0 inch. Scanning objects deeper than this can damage the probe or produce poor quality scans.
-  **ALL MOTORS ARE DISABLED** when the front safety cover is open. The cover must be closed before the machine can proceed.
-  **USE A SUPPORT FOR LONG PIECES TO BE SCANNED AND ALSO FOR SCANNING SLEDS.** To minimize the risk of over stressing the machine, use sturdy roller stands (not included) for support when scanning long pieces more than 36 inches in length.
-  **WHEN LOADING THE PIECE TO BE SCANNED,** there are several critical checks to make before proceeding.
 - Do not attempt to load a piece to be scanned (or sled) that has a significant taper to the sides. A tapered workpiece will bind between the sliding plate and the squaring plate and will damage the traction drive.
 - Do not attempt to load a piece to be scanned (or sled) that varies in thickness by more than 1/16" along its entire length. Using a workpiece with a larger thickness variation than 1/16" can lead to damage to the machine.
 - Always make sure the Board Tracking Sensor that contacts the bottom of the workpiece (or sled) has a smooth, even surface to follow. This means that the bottom edge area of the workpiece adjacent to the squaring plate is clean, smooth, and even for a width of at least 3/8 inch along the full length of the workpiece.
 - Warped, bowed, or cupped pieces should be used only if this condition is minor and if the Board Tracking Sensor can follow it.
-  **MAKE SURE THAT THE HEAD LOCKING LEVER IS RELEASED** after finishing the scan. If the locking lever is not released the head will not move up and down. The lever is in the locked position if it is rotated out from the face of the machine. It is in the released position if it is flush to the front face of the head.
-  **SMALL PIECES TO BE SCANNED MUST ALWAYS USE A SCANNING SLED.** Any piece to be scanned smaller than 1.5 inches wide x 0.25 inches thick x 7 inches long will require it to be placed on a scanning sled.
-  **TO LOCATE THE MACHINE TOTAL SCAN-TIME,** use the Options shortcut key on the keypad to access the information.
-  **TO LOCATE THE SERIAL NUMBER,** use the Options shortcut key on the keypad to access the information.